

BATTERY CHARGER

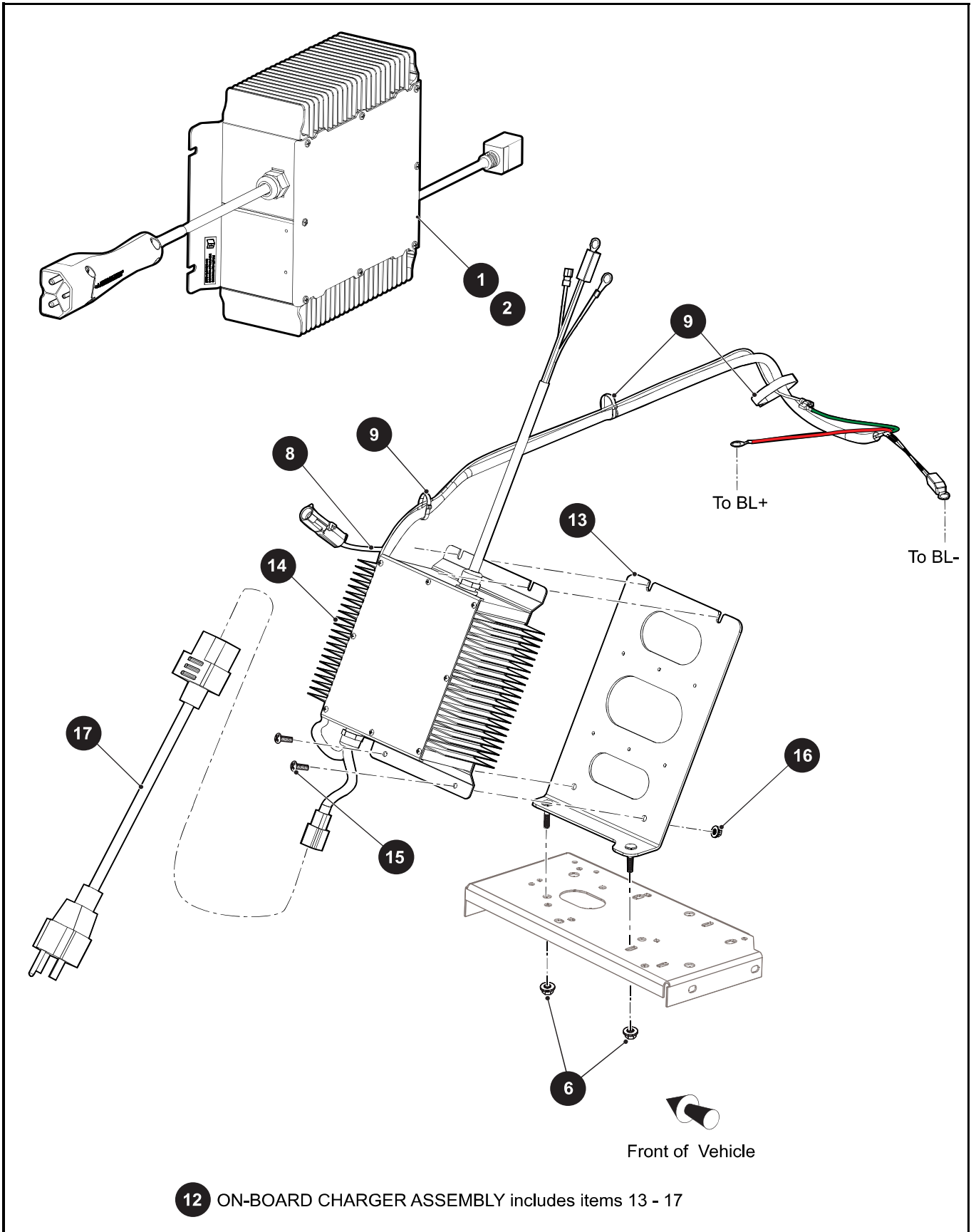

BATTERY CHARGER

When ordering parts, please specify the model and serial number of the product.
 * Indicates a component that is not available as an individual part.
 *** Indicates consult Customer Service Department for additional information.

ITEM	PART NO.	1	2	3	4	5	DESCRIPTION	QTY.
1	622419						WORLD CHARGER, 48V, 3 METER CORD	1
2	622667						WORLD CHARGER, 48V, 5.5 METER CORD	1
3	605834						NYLON CLAMP, 36" (NOT ILLUSTRATED)	2
4								
5								
6	800706						FLANGED LOCK NUT, 1/4" - 20.....	2
7								
8	631543						CHARGER INTERLOCK JUMPER.....	1
9	17618G1						NYLON CLAMP	3
10								
11								
12	638578						ON-BOARD CHARGER ASSEMBLY (INCLUDES ITEMS 13 - 17)	1
13	637104						CHARGER BRACKET.....	1
14	632744						ON-BOARD CHARGER, 48V.....	1
15	16705G3						TRUSS HEAD MACHINE SCREW (SS), 1/4" - 20 X 3/4" LG	4
16	11027G2						FLANGED LOCK NUT, 1/4" - 20	4
17	600462G03						AC CORD, SHIELDED, 6' 7" LG	1