



3 WHEELED
ELECTRIC POWERED
PERSONNEL CARRIER

OWNER'S OPERATION AND SERVICE PARTS MANUAL



MODEL YEAR 1991/1992/1993

MANUAL NO. 33195-G01

ISSUED 1/01/93

**OWNER'S OPERATION AND
SERVICE PARTS MANUAL
3 WHEELED
ELECTRIC POWERED
PERSONNEL CARRIER**

MODEL YEAR 1991,1992,1993

MANUAL NO. 33195-G01 ISSUED 1/01/93

LIMITED WARRANTY

TO OBTAIN A COPY OF THE LIMITED WARRANTY THAT IS APPLICABLE TO YOUR VEHICLE, CALL OR WRITE YOUR LOCAL DISTRIBUTOR, BRANCH, OR E-Z-GO WARRANTY DEPARTMENT.

NOTE

The use of NON E-Z-GO parts may void your warranty.

NOTE

Overfilling of batteries may void your warranty.

GENERAL INDEX

SECTIONS	Page No.
How to use the E-Z-GO Manual	vi

ILLUSTRATED PARTS BREAKDOWN

Illustration	Page No.
WARRANTY	ii
OPERATION AND MAINTENANCE	1
SAFETY PROCEDURES	5
BRAKES	6
BATTERIES	15
CHARGING	19
ELECTRONIC SPEED CONTROL	25
SPECIFICATIONS	43
ILLUSTRATED PARTS BREAKDOWN	45
ACCELERATOR PEDAL AND LINKAGE	46
Accelerator Pedal	
Accelerator Rod	
Accelerator Switch – Resistor Coil Version	
Potentiometer Assembly – Solid State Speed Control Version	
BODY AND ASSOCIATED PARTS	50
Cowl Assembly	
Instrument Panel	
Floormat	
Front Seat Assembly	
BRAKE LINKAGE	56
Brake Pedal	
Brake Yoke	
BATTERY CHARGER, 24 VOLT D.C.	60
Heatsink	
Diode	
Electronic Module Assembly	
FORWARD – NEUTRAL – REVERSE LEVER	66
Contact Board Assembly	
Handle Kit	

GENERAL INDEX

SECTIONS

Illustration	Page No.
ELECTRICAL	70
Lighting	
Components	
Wiring Diagrams	
FRONT STEERING	84
Front Axle Assembly	
Tie Rod Assembly	
Steering Assembly	
HEAVY DUTY ELECTRONIC CONTROLLER AND SOLENOID ASSEMBLY	92
Resistor	
Solenoid	
INNER FRAME AND SUSPENSION	94
Shock Absorber	
MOTOR, 2 H.P.	96
Armature	
Bearings	
Brush	
REAR AXLE	98
Differential	
Axle Shaft	
SEATING	102
Seat Back	
Seat Bottom	
Hinge	
SOLENOIDS AND RESISTORS	106
Solenoid	
Resistor Coils, Heavy and Medium	
Heat Shield	

GENERAL INDEX

SECTIONS

Illustration	Page No.
WHEEL BRAKE	108
Brake Assembly	
Brake Shoes	
Brake Drum	

APPENDIX

SERVICE ACCESSORIES AND SPECIAL TOOLS	Appendix-1
---	------------

HOW TO USE THE E-Z-GO MANUAL

This manual is divided into several sections:

1. OPERATION AND MAINTENANCE
2. ILLUSTRATED PARTS BREAKDOWN FOR ELECTRIC POWERED PERSONNEL CARRIER
3. APPENDIX

The first section, **GENERAL INFORMATION**, contains the following informations:

1. WARRANTY INFORMATION
2. GENERAL INDEX
3. HOW TO USE THE E-Z-GO SERVICE PARTS MANUAL

The second section, **ILLUSTRATED PARTS BREAKDOWN (IPB)** contains illustrations and parts lists for all systems of the electric powered personnel carrier.

The third section, **SERVICE ACCESSORIES AND SPECIAL TOOLS**, contains a listing of E-Z-GO service accessories and special tools that may be purchased from the company to aid in the servicing of the vehicle.

USE OF THE MANUAL

To use this manual, consult the **GENERAL INDEX** (located in the first section) to locate the information or illustration required.

Introduction of some revisions varies due to supply of components; therefore, it is possible that various combinations of components may be found that are not directly reflected by each illustration. Consult the illustration that best suits your situation and contact the Service Parts Department. It is important that the serial number of your vehicle and its model number be supplied to Service Parts when ordering any replacement components.

Locate the serial number plate and note the complete number shown on the plate.

Each system is listed in the index and has an alphabetical prefix. The illustration always appears first and is followed by its related parts list.

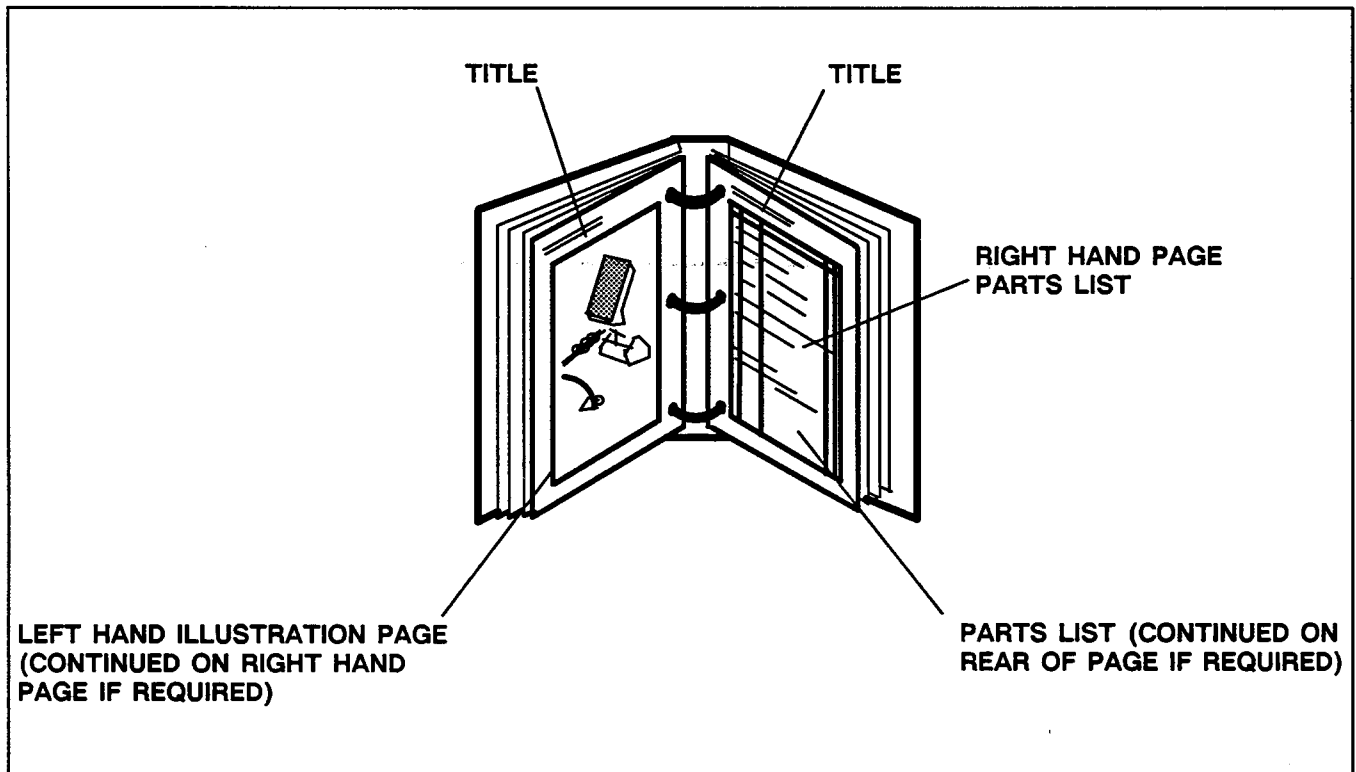

1. WHEN THE PART NUMBER IS *NOT* KNOWN.

- a. Determine the function and application of the part required. Turn to the General Index and select the most appropriate title.
- b. Turn to the page number indicated and locate the desired part on the illustration.
- c. From the illustration, obtain the item number assigned to the desired part. Refer to the accompanying description for specific information regarding the part.

2. IF YOU KNOW THE PART NUMBER.

Locate the part number or description in the appropriate column on the parts list page.

NOTE: It is suggested that you confirm that the part selected is correct by verifying it with the pictorial representation on the illustration page.

Should an asterisk(*) appear in the part number column on the parts list page, read upwards until a part number is found. The part number is the *lowest* assembly sold by E-Z-GO and the asterisk (*) indicates that the part depicted is not available for sale by E-Z-GO.

NOTE: Descriptions are *indented* under the assembly that they are used on. That assembly is, in turn, listed under the assembly that it is used on. This process is repeated until the highest or *final assembly* is reached.

HOW TO USE THE E-Z-GO MANUAL

OPERATION AND MAINTENANCE

XI-835

GENERAL

The model, serial, manufacturing and capacity numbers are stamped on a plate that is permanently attached to the E-Z-GO vehicle.

Always provide these numbers to the dealer when ordering parts for the vehicle.

CONTROLS

The controls of the E-Z-GO vehicle consist of a Key Switch, Forward-Neutral-Reverse Lever, Accelerator Pedal, Service Brake and Foot Operated Parking Brake.

KEY SWITCH

Located on the seat support panel, this switch enables the basic electrical system of the vehicle to be turned off by turning the key to the "OFF" position.

For added security, when the vehicle is left unattended the key may be removed from the "OFF" position preventing inadvertent operation of the vehicle.

NOTE: If the vehicle is equipped with E-Z-GO installed custom accessories, some accessories remain operational with the ignition switch in the "OFF" position.

FORWARD-NEUTRAL-REVERSE LEVER

Located on the seat support panel, this lever permits the selection of either forward, neutral, or reverse.

CAUTION: WHEN SELECTING DIRECTION DESIRED, BOTH THE VEHICLE AND THE MOTOR MUST BE COMPLETELY STOPPED BEFORE MOVING THE LEVER.

ACCELERATOR PEDAL

NOTE: Depressing the vehicle accelerator pedal starts the motor. Each time the pedal is released, the motor will stop.

PARKING BRAKE

The foot operated control is located beside the driver's left foot. The brake is engaged when the pedal is depressed and disengaged when the handle is pulled to release the foot pedal.

BEFORE STARTING

Be sure you understand the vehicle, its equipment, and how to use it safely. Although E-Z-GO vehicles have been designed to provide you with a safe and reliable vehicle, maintaining its good performance depends to a large extent on the operator.

CAUTION: IMPROPER USE OR OPERATION OF THE VEHICLE OR THE LACK OF PROPER MAINTENANCE MAY RESULT IN DECREASED PERFORMANCE OR DAMAGE TO THE VEHICLE.

CAUTION: BEFORE INITIAL USE, REMOVE PROTECTIVE PLASTIC SEAT COVERINGS.

BEFORE ENTERING VEHICLE

1. Check for correct tire inflation.
2. Inspect for fluid leaks.
3. Be certain that everything is properly stored and secured.

NOTE: Read and understand the following warnings before attempting to operate the vehicle.

WARNING: WHEN THE VEHICLE IS TO BE LEFT UNATTENDED, TURN KEY TO "OFF" POSITION, REMOVE KEY AND ENGAGE PARKING BRAKE. MOVE FORWARD-NEUTRAL-REVERSE SWITCH TO THE 'N' POSITION.

TITLE: OPERATION AND MAINTENANCE

WARNING: DRIVE THE VEHICLE ONLY AS FAST AS TERRAIN AND SAFETY CONSIDERATIONS ALLOW. CONSIDER THE TERRAIN AND EXISTING TRAFFIC CONDITIONS. ALSO CONSIDER THE ENVIRONMENTAL FACTORS WHICH AFFECT THE TERRAIN AND YOUR ABILITY TO HANDLE THE VEHICLE.

WARNING: AVOID DRIVING FAST DOWN-INCLINES. SUDDEN STOPS OR CHANGE OF DIRECTION MAY RESULT IN A LOSS OF VEHICLE CONTROL. USE BRAKE TO CONTROL SPEED WHEN TRAVELING DOWN AN INCLINE.

WARNING: USE EXTRA CARE AND REDUCED SPEED WHEN DRIVING ON POOR SURFACES, SUCH AS WET PAVEMENT, GRAVEL, ETC.

WARNING: ALL TRAVEL IN CONGESTED AREAS AND WHEN OPERATING IN REVERSE SHOULD BE DIRECTLY UP OR DOWN INCLINES.

WARNING: AVOID STEEP INCLINES. USE THE PARKING BRAKE WHENEVER THE VEHICLE IS PARKED.

WARNING: KEEP ALL BODY PARTS INSIDE THE VEHICLE AT ALL TIMES.

WARNING: AVOID ROUGH TERRAIN.

WARNING: CHECK THE AREA BEHIND THE VEHICLE BEFORE BACKING UP.

WARNING: MAKE SURE THAT FORWARD-NEUTRAL-REVERSE LEVER IS IN CORRECT POSITION BEFORE ATTEMPTING TO START VEHICLE.

WARNING: SLOW DOWN BEFORE AND DURING TURNS. ALL TURNS SHOULD BE EXECUTED AT REDUCED SPEED.

- o Always bring the vehicle to a complete stop before shifting the forward-neutral-reverse control.

WARNING: STANDARD VEHICLE IS LIMITED TO 2 OCCUPANTS.

WARNING: ALWAYS REMAIN SEATED AND HOLD ON WHILE VEHICLE IS IN MOTION.

STARTING THE E-Z-GO ELECTRIC VEHICLE

To start the E-Z-GO electric vehicle, apply the parking brake; place the forward-neutral-reverse lever in neutral; place the key in the ignition switch and turn to the "ON" position; move forward-neutral-reverse lever to the direction desired; release parking brake, and depress the accelerator pedal to start the motor.

NOTE: When the lever is in the reverse position, a warning will sound. This is a device to indicate that the vehicle is ready to start and run in reverse.

When the accelerator pedal is released, the motor stops. To stop the vehicle more quickly, depress the brake pedal.

When leaving the vehicle unattended, engage the parking brake by engaging the foot pedal on the driver's left side.

To change direction, bring the vehicle to a complete stop. Then shift the forward-neutral-reverse lever to the direction desired. Proceed by depressing the accelerator pedal.

CAUTION: TO AVOID COMPONENT DAMAGE, THE VEHICLE **MUST** BE BROUGHT TO A COMPLETE STOP BEFORE SHIFTING THE FORWARD-NEUTRAL-REVERSE LEVER.

TOWING

CAUTION: MAXIMUM TOWING SPEED IS 9 M.P.H.

CAUTION: IT IS IN THE BEST INTEREST OF BOTH THE VEHICLE OWNER AND SERVICING DEALER TO CAREFULLY FOLLOW THE PROCEDURES RECOMMENDED IN THIS MANUAL. ADEQUATE PREVENTATIVE MAINTENANCE APPLIED AT REGULAR INTERVALS IS THE BEST GUARANTEE FOR KEEPING THE E-Z-GO ELECTRIC VEHICLE BOTH DEPENDABLE AND ECONOMICAL.

SERVICING A NEW ELECTRIC VEHICLE

Before a new vehicle is put in operation, it is recommended that the owner make a check of the items shown in the INITIAL SERVICE CHART.

TITLE: OPERATION AND MAINTENANCE

Service operations are described in pertinent sections of the Service Manual.

INITIAL SERVICE CHART	
Item	Service Operation
Batteries	Check charge condition.
Seats	Remove protective plastic covering.
Brakes	Check operation and adjust if necessary.
Tires	Check pressure.

SEATS

Preparation of Seats for Service

Remove the protective plastic coverings from seats before placing vehicle in service. The function of the plastic coverings is to protect the seat bottoms and back rest during shipping. If the plastic covering is left on the seats and gets torn, dirt getting under the plastic covering is ground in to the cover material. Water getting under the plastic covering is trapped and eventually will damage the seat assembly.

TIRES

Tire condition should be inspected on a daily basis. See Specifications for recommended pressure.

Inflation pressures should be checked on a weekly basis when the tires are cool. All tires should have the same pressure for optimum handling characteristics. Be careful not to overinflate. Due to the low volume of these small tires, overinflation can occur in a matter of seconds. Be sure to replace the valve dust cap after checking or inflating.

PREVENTATIVE MAINTENANCE

E-Z-GO suggests that preventative maintenance be performed under the following headings: Daily, Weekly, and Semi-Annually.

DAILY CHECK LIST

After the E-Z-GO vehicle has been put into service, it is recommended that the following items be checked daily by the personnel handling the vehicles. Personnel driving vehicles can be an asset to a proper maintenance program if trained to look, listen, and feel for an unusual situation. This practice can be a great help in solving many maintenance problems in the minor stages while they can be corrected by simple adjustments.

- A. Examine vehicle for damage or anything unusual to normal wear and tear.
 - o Torn seats.
 - o Cuts in tires.
 - o Mechanical damage, rods, etc.
 - o Be sure that the engaged parking brake will hold on an incline and that when disengaged, does not drag or prevent the vehicle from rolling freely.
 - o Check the tires for wear and proper air pressure.
 - o Assure that all switches are operating normally.
 - o Make sure that service brakes operate properly.
 - o Listen for any noise, such as rattles due to loose hardware; scraping sounds such as brakes dragging, etc.; unusual motor noises, and be sensitive to abnormal performance.
- B. Clean vehicle.
 - o Wipe seats.
 - o Remove trash from dash tray.
 - o Visually check the appearance of the vehicle for dents, scratches, loose equipment.
 - o Wash accumulated dirt from motor compartment and underbody.

TITLE: OPERATION AND MAINTENANCE

SEMI-ANNUAL MAINTENANCE

- o Lubricate all moving linkages such as:
 1. Accelerator pivot points.
 2. Brake linkage bushings.
 3. Steering gear and wheel bearings.
 4. Fork pivot bearings.
- o Wash batteries, when required, using baking soda and water to remove corrosion.

2. Parking Brake - Check for proper engagement and release. Check for abnormal brake travel.

Time interval - once every 3 months (50 hours) or as needed.

3. Brake Drum and Brake Shoes - Inspect for wear on brake shoes and brake drum. Inspect for scoring, scratches, or unusual sightings in shoes and drum.

Time interval - every 6 months (100 hours).

FRONT SUSPENSION

1. Front axle - Inspect for damage to the axle and for loose hardware or excessive play in bearings.

Time interval - 6 months (100 hours).

REAR SUSPENSION AND AXLE

1. Rear Axle and Housings - Inspect for abnormal noise, loose connections at shocks, and oil leakage from differential housing. Inspect rear coil springs for damage and loose hardware.

Time interval - every 6 months (100 hours).

WHEELS AND TIRES

1. Wheel - Inspect for proper tire pressure, abnormal wear, cracks or damage to tread area, tightness of lug nuts, dented or damaged wheel rims.

Time interval - every 3 months (50 hours).

ELECTRICAL SYSTEM

1. Batteries - Check for low electrolyte and corrosion build-up.

Time interval - bi-weekly (40 hours).

2. Wiring - Inspect all wiring for loose connections, cracked and/or worn insulation.

Time interval - semi-annually (100 hours).

PERIODIC CHECK LIST

The following inspections should be routinely done on the schedule indicated.

STEERING

1. Gear Box - Assure that all mounting bolts are securely in place. Inspect for abnormal play in steering shaft and/or steering wheel.

Time interval - once every 6 months (100 hours).

2. Tie rods and Pitman arms - Inspect for excessive play, bends or loose connections.

Time interval - once every 3 months (50 hours).

3. Front Wheel alignment - Inspect axle fork alignment.

Time interval - once every 6 months (100 hours or more often if handling is unusual or tire wear is uneven).

4. Lubricate grease fittings (4).

Time interval - every 6 months (100 hours)

BRAKES

1. Brake Pedal - Check for smooth operation of pedal.

Time interval - once every 6 months (100 hours).

TITLE: OPERATION AND MAINTENANCE

3. Reverse Warning - Check for proper operation.

Time interval - daily.

4. Forward-Neutral-Reverse Switch - Check for wear and lubricate.

Time interval - semi-annually (100 hours).

5. Motor Brushes - Check with gauge. E-Z-GO P/N 17219-G1 inserted into brush measurement holes. Replace brushes if gauge can be inserted 1.56" or more.

Time interval - semi-annually (100 hours).

6. Battery Charger - Use a dry brush to clean ventilation slots in battery charger housing.

Time interval - semi-annually (100 hours).

MISCELLANEOUS

Inspect all lubrication areas around pedal shafts, chassis parts, etc.

CARE AND CLEANING OF THE VEHICLE

It is very important that proper techniques and cleaning materials be used.

Ordinary cleaning of vinyl seats and plastic or rubber trim requires the use of a mild soap solution applied with a sponge or soft brush and the subsequent removal of the material with a damp cloth.

Removal of oil, tar, asphalt, shoe polish, and so forth will require the use of a commercially available vinyl/rubber cleaner.

The painted surfaces of the vehicle provide attractive appearance and durable protection. Frequent washing with lukewarm or cold water is the best method of preserving those painted surfaces.

Do not use hot water, strong soap, or harsh chemical detergents.

Occasional cleaning and polishing with appropriate materials will enhance the appearance and durability of the painted surfaces.

Corrosive materials used for dust control can collect on the underbody of the vehicle. These materials will accelerate corrosion of underbody parts. It is recommended that the underbody be flushed occasionally with plain water. Thoroughly clean any areas where mud or other debris can collect. Sediment packed in closed areas should be loosened to expedite their removal.

SAFETY PROCEDURES

When performing any inspection or maintenance work on the vehicle, always exercise care to prevent accidental personal injury to yourself or damage to the vehicle.

The following are general precautions which should be closely observed in carrying out any servicing operation.

- o Set the parking brake.
- o Do not work on the motor while connected to batteries.
- o When working near batteries, remove any jewelry, such as rings, watch, etc.
- o Never get under the vehicle while it is supported by a jack. If it is necessary to work under the vehicle, use safety stands.
- o Never raise the rear of the vehicle without first supporting both sides of the forward portion of the chassis with jack stands.
- o Keep smoking materials, flame or sparks away from the batteries.
- o Never connect or disconnect either the batteries or any electrical component while the key is in the on/off switch.
- o When connecting the battery cables, pay particular attention to their polarities. Never confuse the positive posts with the negative posts.

TITLE: OPERATION AND MAINTENANCE

HOW THE BRAKE WORKS

The brake assembly is a servo action brake.

The brake assembly is a self-adjusting unit and should not require any adjustment. Periodic adjustment to the actuating linkage may be required to compensate for component wear or as a result of a component replacement.

Depressing the brake pedal causes the brake cable to pull the brake actuating lever forward which in turn pushes the rear brake shoe against the brake drum. Continued movement of the brake actuating lever causes the lever slide mechanism to move which pushes the front shoe against the drum. As the shoes contact the drum "servo action" takes place. If the vehicle is moving forward the rear brake shoe

moves upwards applying pressure against the upper rear portion of the brake drum. The front shoe moves downwards applying pressure against the lower front portion of the brake drum.

The action reverses when the brakes are applied with the vehicle operating in reverse.

The resulting brake shoe wear is shown (Fig. 1) in quadrants A, B, C and D with quadrant 'A' showing the most wear, 'B' will show the second most wear. Quadrants B and D will always be to the rear of the vehicle.

Brake shoes must be replaced when the lining thickness (measured at the point of greatest wear) reaches .040 thick.

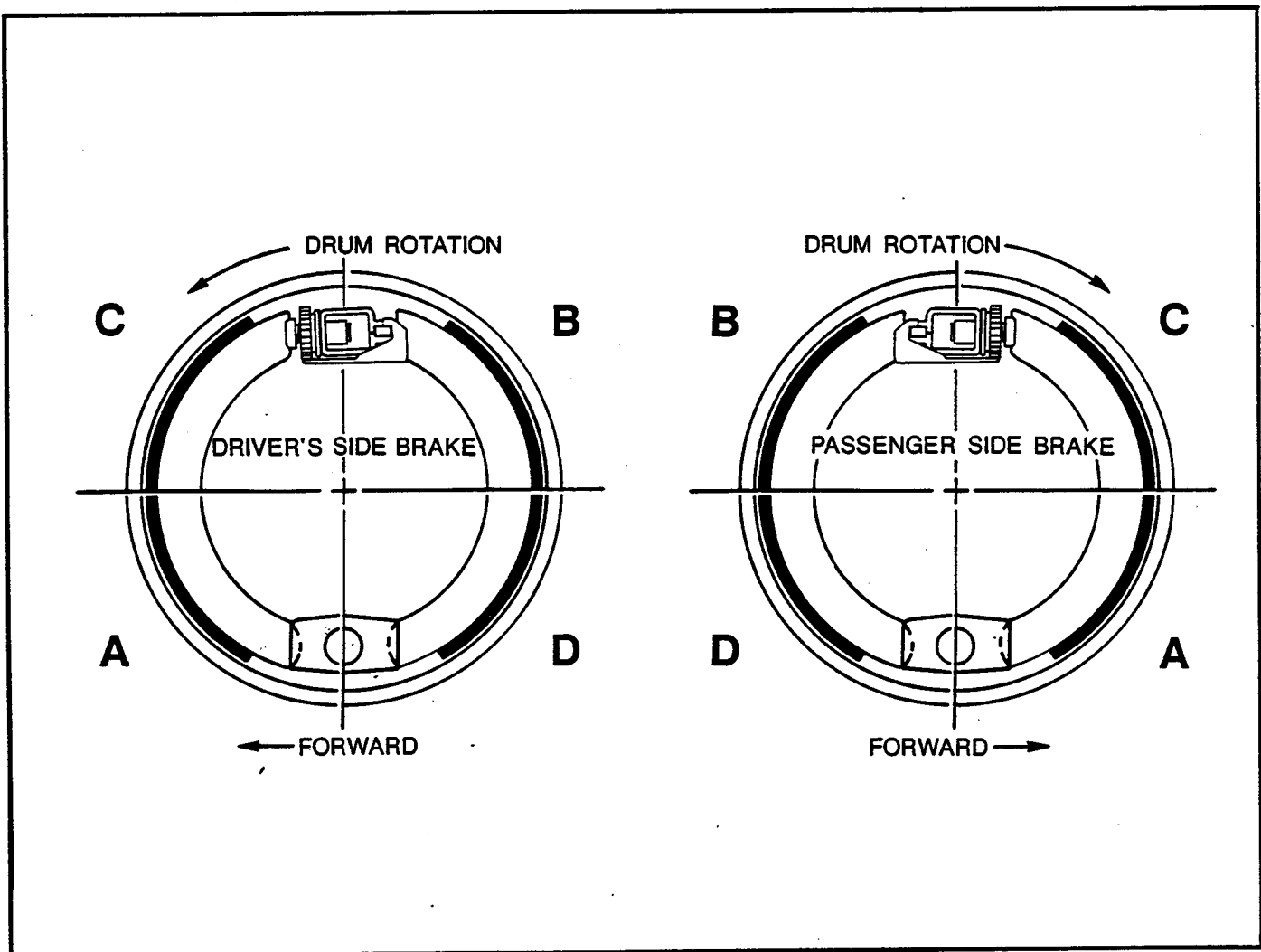

FIG. 1 BRAKE WEAR

An overall view of the brake system is shown in Fig. 5.

HOW THE ADJUSTER WORKS (Fig. 2)

The brake has an automatic adjusting mechanism that compensates for lining wear.

The brake adjuster is activated by movement of the lever attached to the brake cable. Movement of this lever activates the inner lever (1) which rotates the 'star' wheel (2). The star wheel's rotation pushes the adjusting screw (3) outwards which in turn moves the brake shoes outward. With the brake correctly adjusted, the inner lever does not have enough movement to rotate the star wheel since lever movement is limited to approximately 1/8". The 1/8" of movement limits the inner levers motion to the flat of the tooth that it is sitting on.

As the brake shoe wears the lever's motion increases which causes the inner lever to engage the next tooth of the star wheel. The wheel is then rotated which expands the brake shoes.

MEASURING BRAKE PEDAL FREE PLAY (Fig. 3)

Periodically the brake linkage will have to be readjusted to compensate for wear to the brake system components such as the cables, clevis pins, etc. These components are not part of the self-adjusting brake unit.

Pedal free travel is adjusted by changing the length of the linkage that is located below the floorboard. To measure the free travel, place the end of a ruler against the floorboard,

alongside the brake pedal. Apply hand pressure to the pedal and push down until resistance is felt. The distance the pedal travels is free play and should be 1" to 1 1/4".

ADJUSTING BRAKE PEDAL FREE PLAY (Fig. 4)

Loosen the lock nut (1) behind the yoke (2) and adjust the linkage with the nut (3) inside the yoke. Tighten the lock nut (1) after the correct free travel has been achieved.

BRAKE PEDAL DISASSEMBLY (Fig. 5)

Tools Required:

- Straight Blade Screwdriver . . . Quantity 1
- Pliers Quantity 1
- Ball Peen Hammer Quantity 1

To repair or replace any damaged or worn brake pedal parts, disassemble as follows: Unhook the wiring harness to the brake pedal switch. If the pedal is to be removed the floor mat may be removed by pushing the pin in each rivet upwards (using small screwdriver) and then removing the rivet. Unhook the pedal return spring (1) by hooking a thin blade screwdriver between the small hook at the end of the spring and the pedal bracket; move the spring back and away from the bracket.

Remove the cotter pin (2) from the pivot shaft (3) at the pedal bracket bushing. Pull out the pivot shaft and remove the spring. Remove the cotter pins (4) from the clevis pins (5) and separate the linkage rods (6) and (7).

The pedal assembly may be removed through the floorboard.

ILLUSTRATIONS SHOW DRIVER'S SIDE BRAKE ONLY. PASSENGER SIDE IS MIRROR IMAGE.

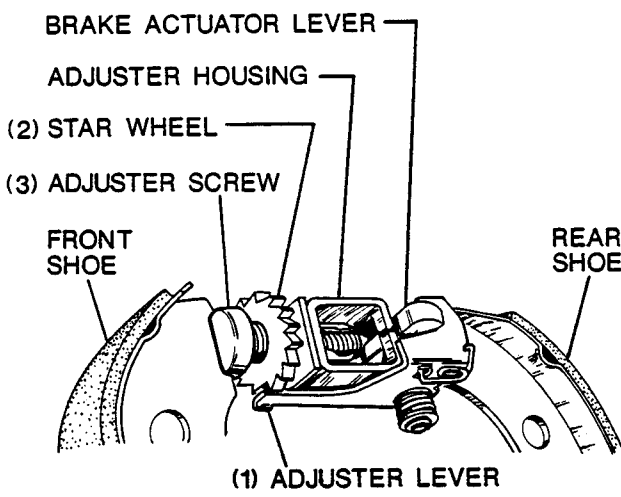
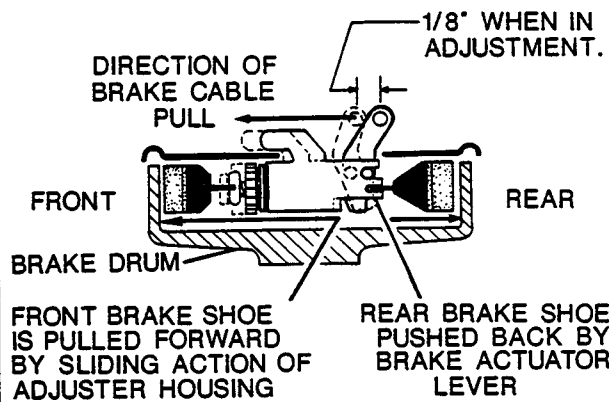

NOTE: TEETH ARE NUMBERED IN ILLUSTRATION TO CLARIFY THEIR POSITIONS.

THE DISTANCE OF THE ADJUSTER LEVER TRAVEL IS REGULATED BY THE AMOUNT OF BRAKE SHOE WEAR.(A)

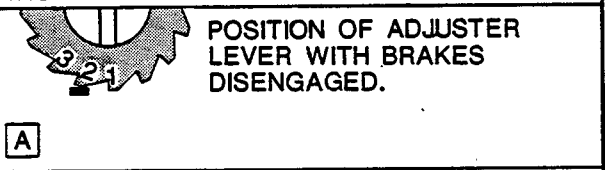

WHEN BRAKE SHOE WEAR IS MINIMAL, THE DISTANCE OF ADJUSTER LEVER TRAVEL IS TOO SHORT TO FULLY RE-ADJUST BRAKES.(B)

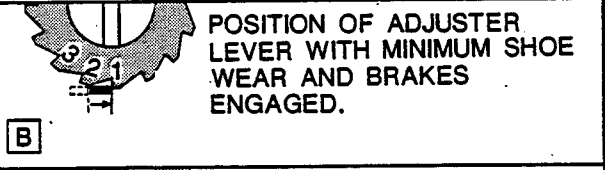

AS SHOE WEAR INCREASES, ADJUSTER LEVER TRAVEL INCREASES, THUS TURNING THE STAR WHEEL.(C)

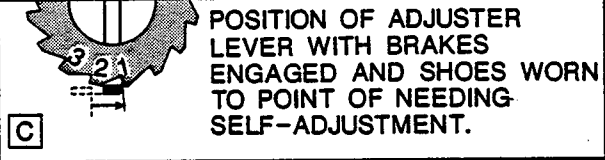

WHEN BRAKE SHOES HAVE WORN SUFFICIENTLY TO REQUIRE RE-ADJUSTMENT, THE ADJUSTER LEVER ADVANCES AND RATCHETS TO THE NEXT TOOTH WHEN BRAKES ARE RELEASED.(D)

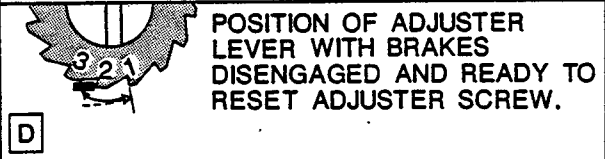

WHEN BRAKE IS NEXT ENGAGED, THE ADJUSTER LEVER WILL ROTATE THE STAR WHEEL FAR ENOUGH TO EXTEND THE ADJUSTER SCREW, THUS RE-SETTING THE PROPER SHOE/DRUM CLEARANCE.(E)

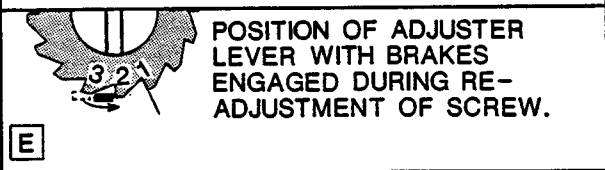

WHEN THE SHOE/DRUM CLEARANCE IS RESET, LESS EFFORT IS REQUIRED TO ENGAGE THE BRAKES, THUS THE ADJUSTER LEVER TRAVEL IS ONCE AGAIN REDUCED.(F,A)

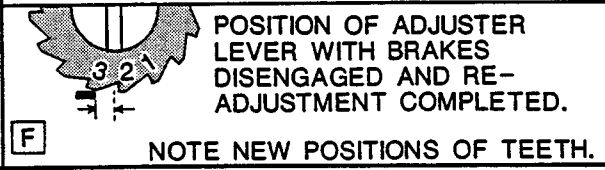

FIG. 2 HOW THE BRAKE ADJUSTER WORKS

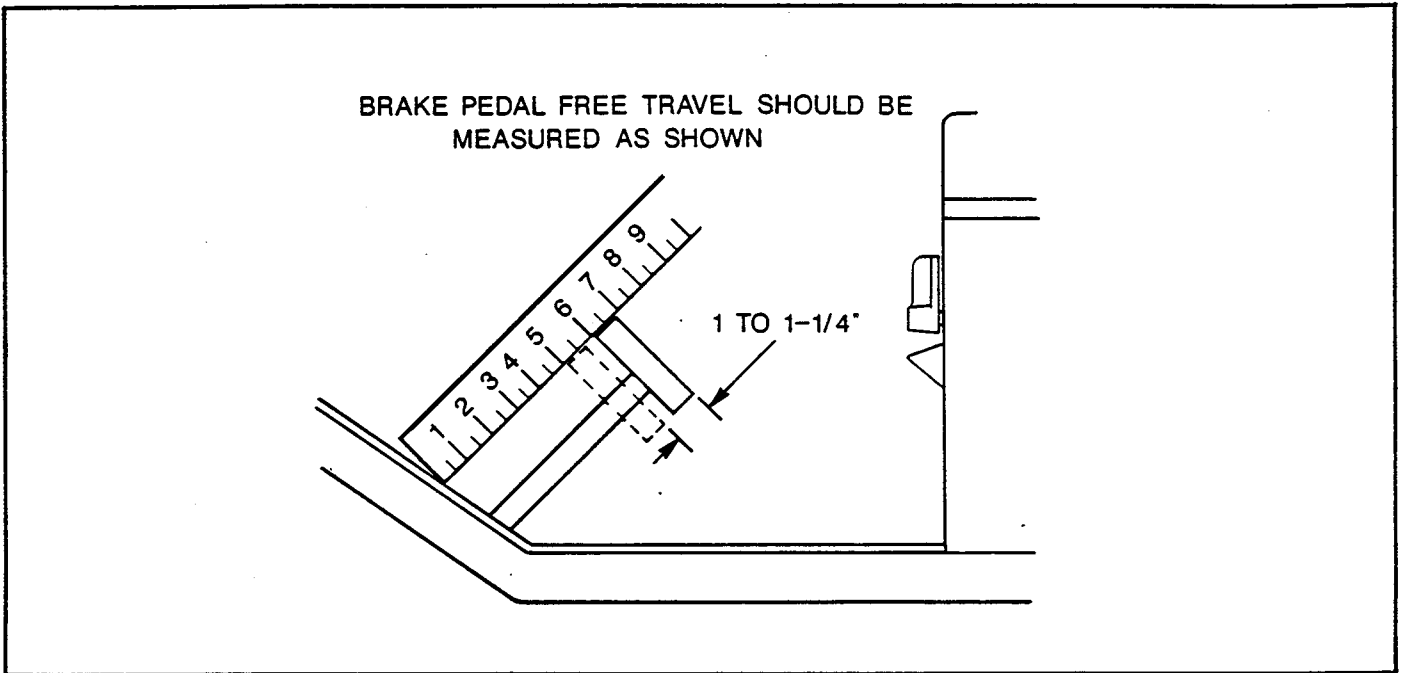

FIG. 3 MEASURING BRAKE PEDAL FREE PLAY

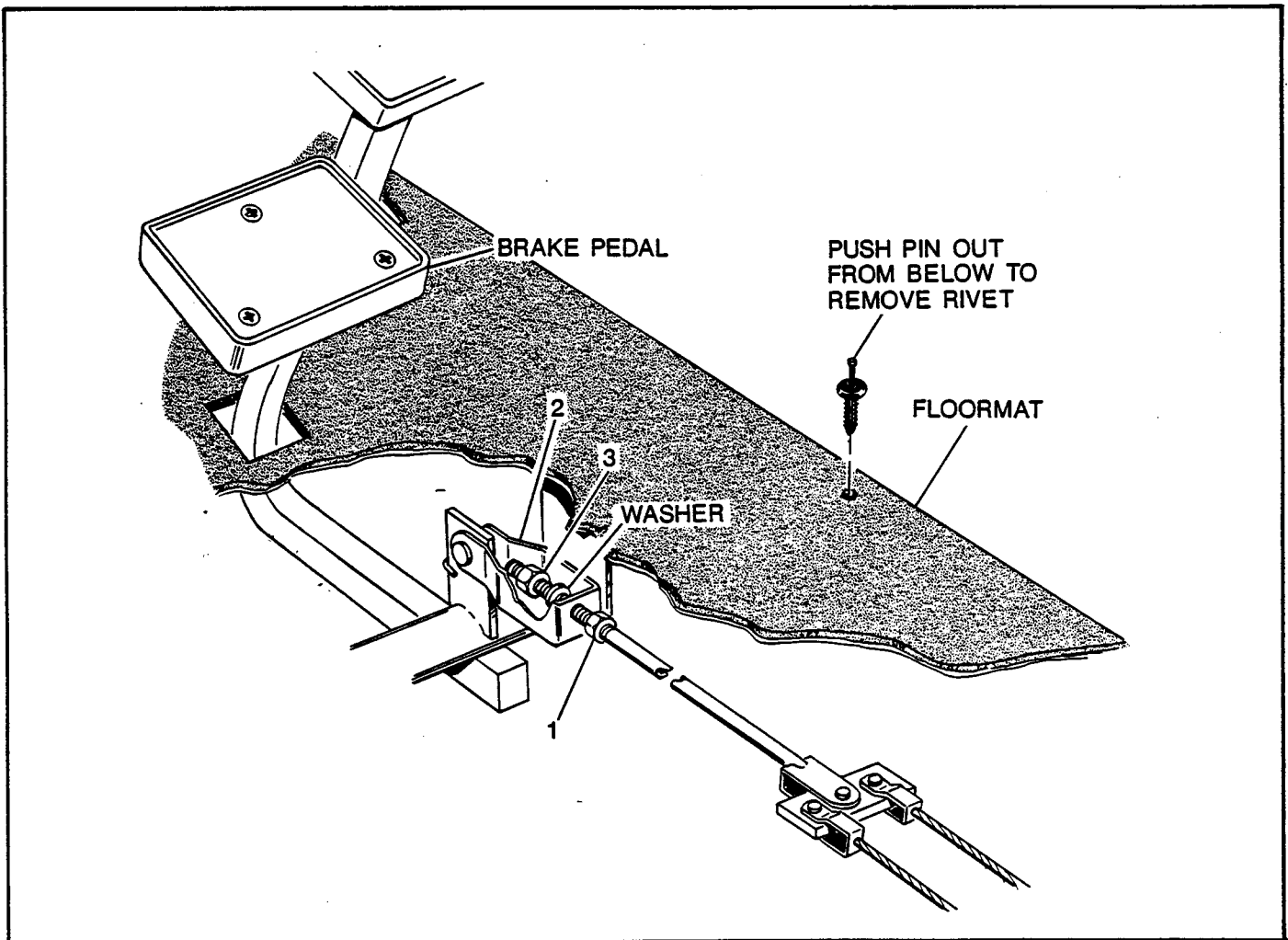

FIG. 4 ADJUSTING BRAKE PEDAL FREE PLAY

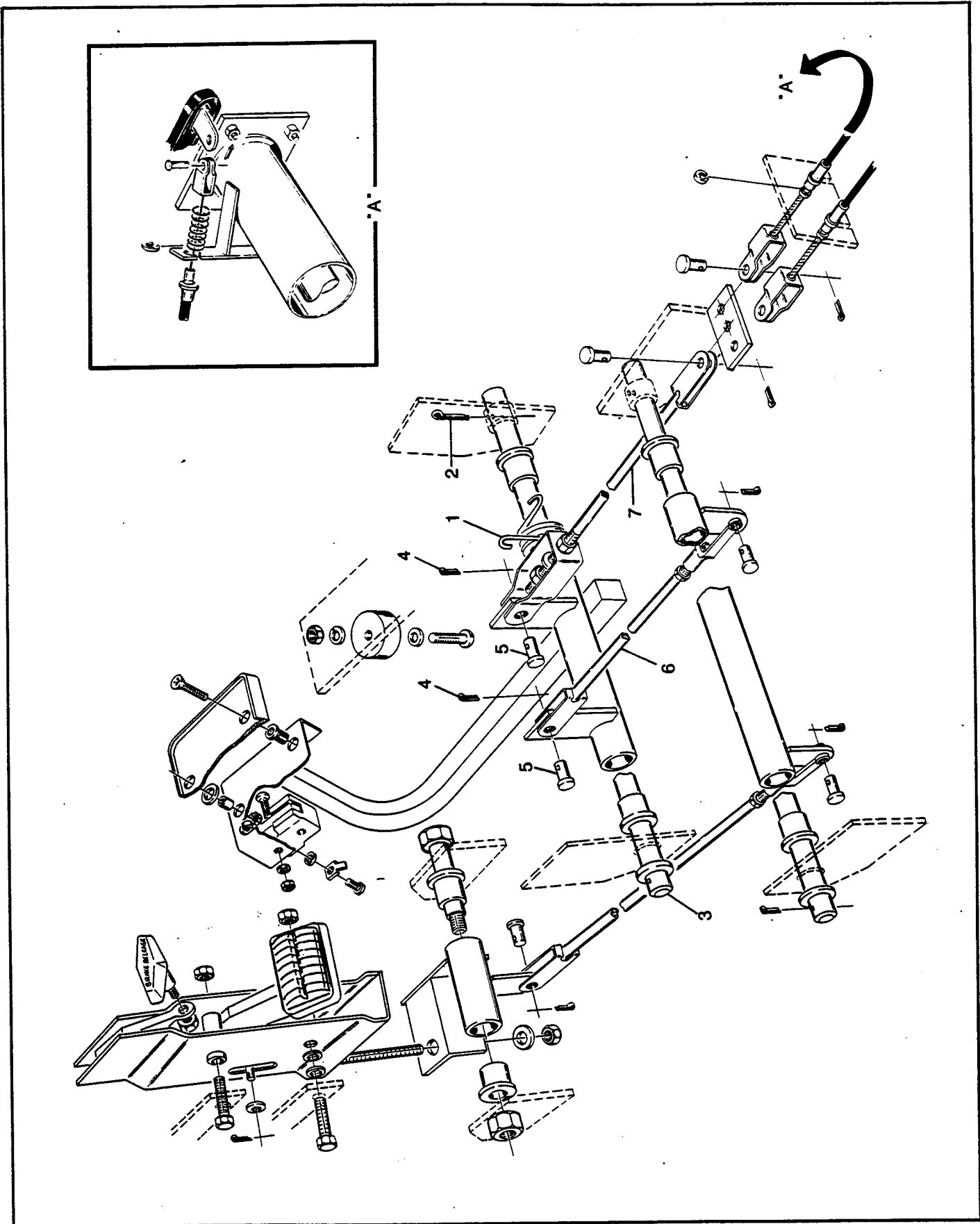

FIG. 5 BRAKE LINKAGE

BRAKE DRUM, SHOE AND BRAKE ASSEMBLY REMOVAL (Fig. 6 and 7)

Tools Required:

- Hydraulic Trolley Jack Quantity 1
- Plastic Tipped Hammer Quantity 1
- Jack Stands Quantity 4
- Flat Blade Screwdriver Quantity 2
- 1/2" Socket Quantity 1
- 1/2" Drive Ratchet Quantity 1
- 1 1/16" Socket Quantity 1
- Torque Wrench Quantity 1
- Pliers Quantity 2
- 1/2" Wrench Quantity 1

DRUM REMOVAL

Loosen lug nuts on rear wheels 1/8 to 1/4 turn. Lift the vehicle and place on FOUR jack stands.

WARNING: TO PREVENT POSSIBLE INJURY, LIFT THE FRONT OF THE VEHICLE AND PLACE ON JACK STANDS. RAISE THE REAR OF THE VEHICLE AND PLACE ON JACK STANDS. NEVER LIFT THE REAR OF THE VEHICLE FIRST. LOWER THE REAR OF THE VEHICLE FIRST.

Remove The Rear Wheel(s)

Remove the cotter pin (5) and clevis pin (6) from the brake lever. Remove the cotter pin (8) from the axle nut (9) and remove the nut and washer (10). **TAP** the brake drum (11) with a plastic faced hammer to remove the drum. If the drum does not come off, it will be necessary to loosen the brake adjusting mechanism.

Rotate the brake drum until one of the holes is located over the 'star' wheel position. (11 o'clock for driver's side; 1 o'clock for passenger side).

The hole is aligned with the brake adjusting mechanism when in this position. Insert a flat blade screwdriver between the inner lever and the adjusting screw housing. Insert a second flat blade screwdriver and push on the bottom portion of the 'star' wheel which will loosen the adjusting screw and retract the shoes to permit the drum to be removed.

Using a pair of pliers, compress the brake shoe retainer (1) at the open end of the spring.

While holding the tension pin (2) with a second set of pliers turn the retainer spring 1/4" turn to align the slot in the spring retainer with the flats in the tension pin. Remove the brake shoe retainer springs.

Grasp the brake shoes (3) in the center and tilt them outwards and away from the back mounting plate. This will release the tension in the brake springs (4). Remove the brake springs and remove the brake shoes.

Check for free lateral (front to back) movement of the adjusting mechanism and for free movement of the 'star' wheel. Remove the boot on the brake lever. Clean any accumulated brake dust from the backing plate and adjuster mechanism using a brush or air hose.

WARNING: WEAR PROTECTIVE GOGGLES AND MASK WHEN CLEANING BRAKE COMPONENTS. LUBRICATE AREAS INDICATED WITH WHITE LITHIUM GREASE. (FIG. 8)

If the brake is being removed for an axle bearing and seal replacement the four bolts and nuts securing the brake assembly to the rear axle must be removed. When reinstalling the brake mounting bolts tighten to 23-35 ft. lbs. torque.

REPLACING BRAKE SHOES (Figs. 6 and 7)

Inspect brake shoes. If a brake shoe has less than .040 lining material thickness **AT ANY POINT** on the shoe then the shoe set must be replaced.

NOTE: That metal portion of the brake shoes differs between front and rear shoes. The identical ends of the shoes fit against the fixed anchor at the bottom of the brake. The shoe with the straight end engages in the slot in the adjusting screw, while the triangular ended shoe engages in the rear of the adjusting mechanism.

The springs must be inserted with the light spring at the top. The long hook is installed down through the rear brake shoe. The heavier bottom spring is installed with the spring hooks facing up.

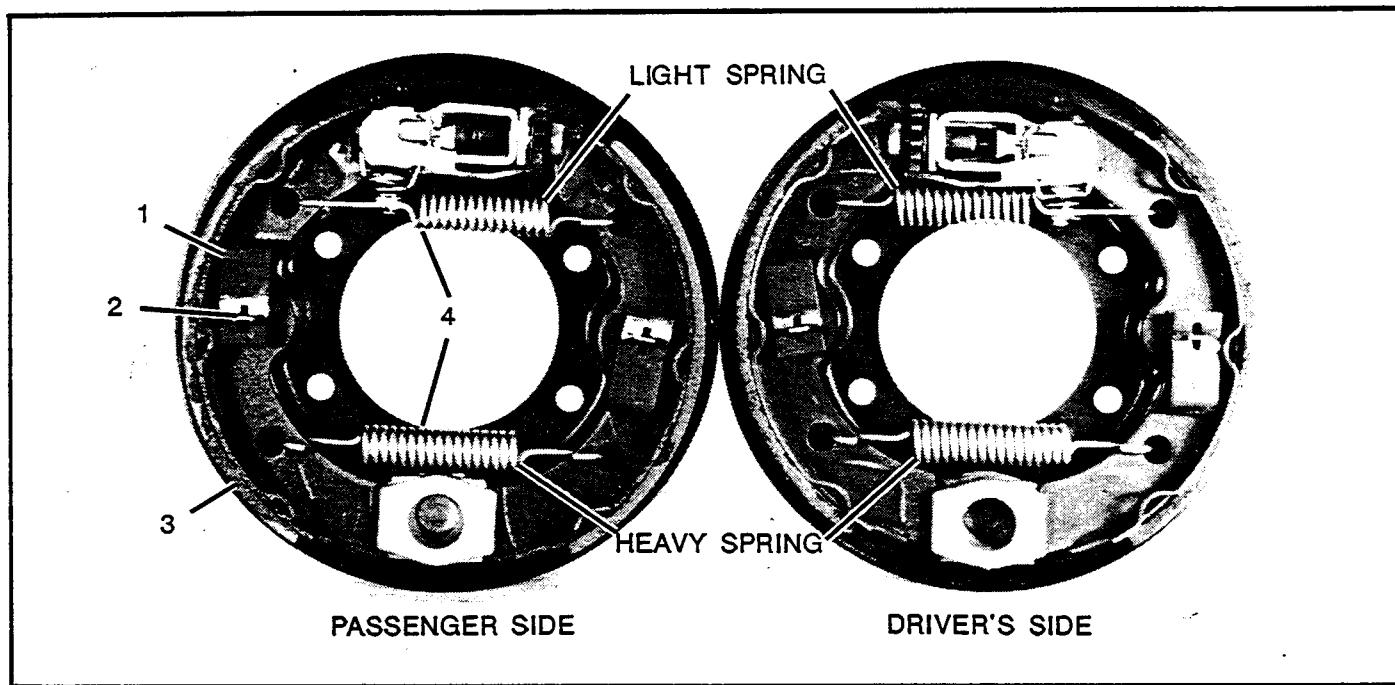

FIG. 6 WHEEL BRAKES DRIVER'S AND PASSENGER SIDE

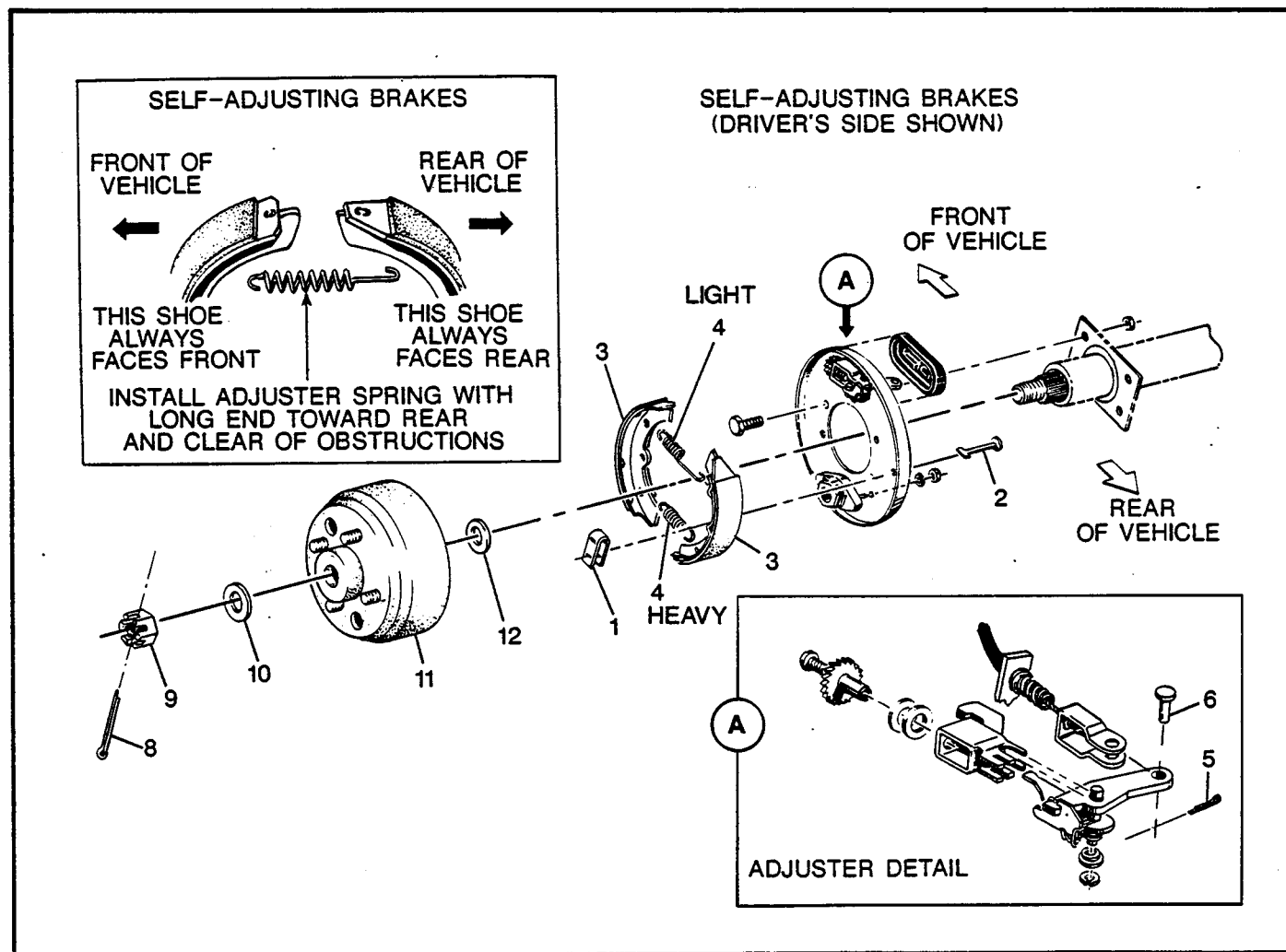

FIG. 7 WHEEL BRAKE COMPONENTS

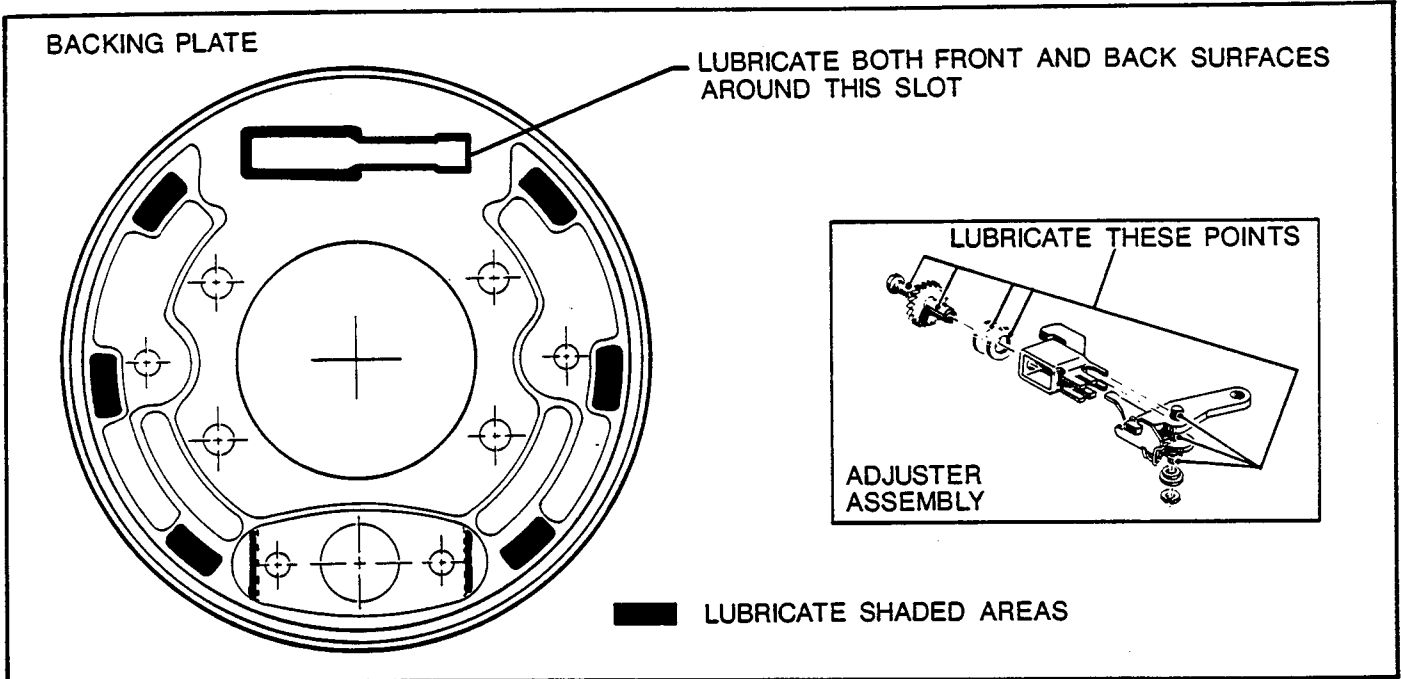

FIG. 8 BRAKE LUBRICATION AREAS

Install the brake shoes using the reverse order of disassembly and secure with the spring retainer and springs.

Clean the axle shaft to remove grease, dirt and all foreign matter. Apply a small amount of lubricant (Neverseize) to the spline.

Insert a straight bladed screwdriver between the adjusting lever and the adjusting mechanism. Rotate the star wheel counter clockwise until the shoes have retracted sufficiently to permit the brake drum to be installed. Install washer (12), brake drum (11), washer (10), and tighten the axle nut to 70 ft. lbs. torque minimum.

If the slot in the axle nut and the hole in the axle are not in alignment, continue to tighten the axle nut until the alignment is achieved.

NOTE: Minimum torque is 70 ft. lbs. Torque readings of up to 140 ft. lbs. are satisfactory.

Install new cotter pin (8).

Move the brake lever forward and release fully, repeat until the travel of the lever is approximately 1/8". Install brake cables using clevis pin (6) and a new cotter pin (5).

Check the pedal free travel and readjust if greater than 1 1/4".

Depress the brake pedal and fully release twenty times.

Check the pedal free travel and adjust if not within the 1" to 1 1/4" range.

Check parking brake operation.

ADJUSTING PARKING BRAKE (Fig. 9)

The foot operated parking brake works in the same way as those found in many automobiles.

Release the parking brake lever.

Before adjusting, the free play in the service brake must be set to the 1" to 1 1/4" range.

Check the clearance between the bellcrank (1) and the support bracket (2). A dimension of 1/16" to 1/8" clearance is acceptable. If an adjustment is required remove the cotter pin (3) and clevis pin (4) from the yoke (5). Loosen the lock nut (6) and adjust the linkage rod by screwing it in or out of the rear yoke (7). Replace the clevis pin (4) and install a new cotter pin (3). Tighten lock nut (6).

Adjust the nut (8) until a dimension of 1/8" to 3/16" is achieved between the washer (9) and the bellcrank (1).

FOLLOW STEPS A,B,C,AND D
TO ADJUST BELLCRANK CLEARANCES.

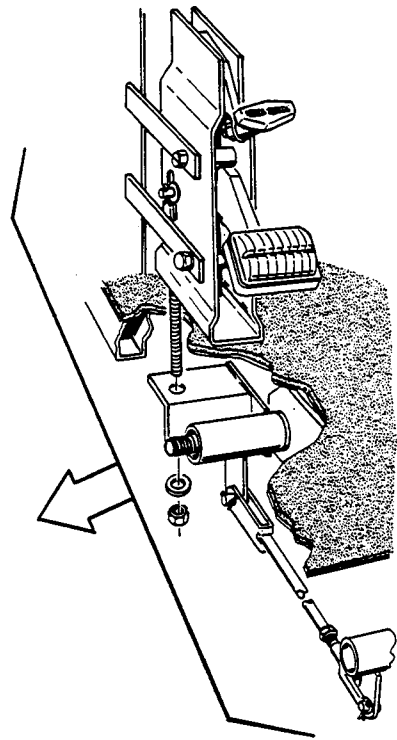

PARKING BRAKE
DETAIL

D ADJUST LOCK NUT
AND WASHER UP OR
DOWN TO ACHIEVE
THIS CLEARANCE.

PEDAL IN RELEASED
POSITION

BRACKET CLEARANCE

1/16"
TO
1/8"

1/8"
TO
3/16"

A LOOSEN LOCK NUT,

B REMOVE COTTER
PIN AND CLEVIS PIN.

C TO ACHIEVE BRACKET CLEARANCE.

ROTATE ROD CLOCKWISE
TO SHORTEN
COUNTER-CLOCKWISE
TO LENGTHEN

FIG. 9 ADJUSTING PARKING BRAKE

BATTERY REMOVAL AND INSTALLATION

Tools Required:

- 7/16" Wrench (Insulated) Quantity 1
- 1/2" Wrench (Insulated) Quantity 1
- Battery Carrying Tool Quantity 1

WARNING: USE INSULATED WRENCHES AND BE CAREFUL NOT TO ALLOW WRENCHES TO CONTACT METAL AREAS OF VEHICLE WHILE WORKING ON BATTERY TERMINALS. OBSERVE BATTERY POLARITY WHEN REINSTALLING CABLES.

Using an insulated wrench, remove all wires from the vehicle batteries. Remove the battery hold downs by removing the hardware and removing the retainer from the threaded hold down bolt and body panel.

Remove the batteries in sequence shown using a battery carrying tool. (Fig. 10)

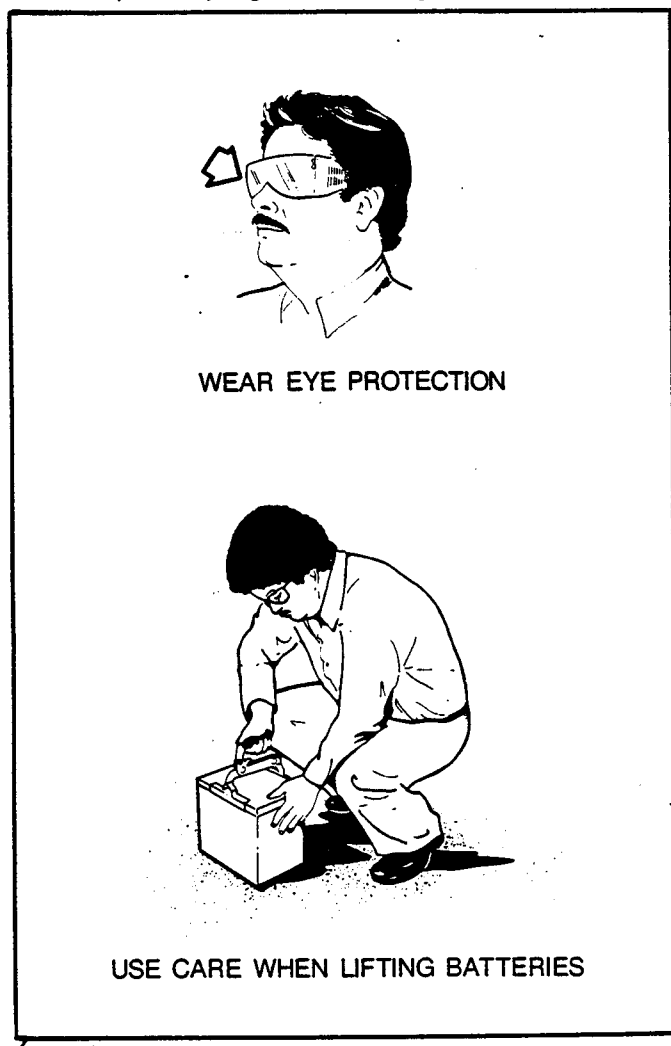

WARNING: BATTERIES ARE HEAVY AND CARE SHOULD BE TAKEN WHEN REMOVING THEM. BE CAREFUL TO LIFT BATTERIES WITHOUT TIPPING THEM, ELECTROLYTE MAY BE SPILLED WHICH COULD CAUSE BURNS OR DAMAGE TO VEHICLE AND CLOTHING. SHOULD ANY ELECTROLYTE BE SPILLED FLUSH THOROUGHLY WITH WATER.

Care must be taken to observe the preceding warnings when reinstalling batteries.

GENERAL BATTERY MAINTENANCE

Electric vehicle batteries require careful maintenance to maximize their useful service life.

WARNING: THE ELECTROLYTE IN A STORAGE BATTERY IS A DILUTE ACID WHICH CAN CAUSE SEVERE BURNS. ALWAYS WEAR SAFETY GOGGLES WHEN ADDING WATER, CHARGING BATTERIES, OR CLEANING BATTERIES. TREAT ALL ELECTROLYTE SPILLS BY EXTENDED FLUSHING WITH CLEAR WATER.

WARNING: HYDROGEN GAS IS FORMED WHEN CHARGING BATTERIES. DO NOT CHARGE BATTERIES WITHOUT ADEQUATE VENTILATION. DO NOT SMOKE IN AN AREA BEING USED FOR CHARGING BATTERIES. CONCENTRATIONS OF 4% HYDROGEN GAS OR MORE IS EXPLOSIVE.

PREVENTATIVE MAINTENANCE

- o Check the electrolyte level at **least** once a week.
- o Inspect all wiring for breaks or deterioration of the insulation.
- o Before charging batteries, inspect all terminations for frayed conductors and loose or damaged connectors.
- o Before charging batteries, inspect all terminations to assure that they are both clean (corrosion free) and securely fastened to battery posts.
- o When adding water, do not overfill (Fig. 11). Overfilling will cause a loss of acid from the electrolyte. Use distilled water

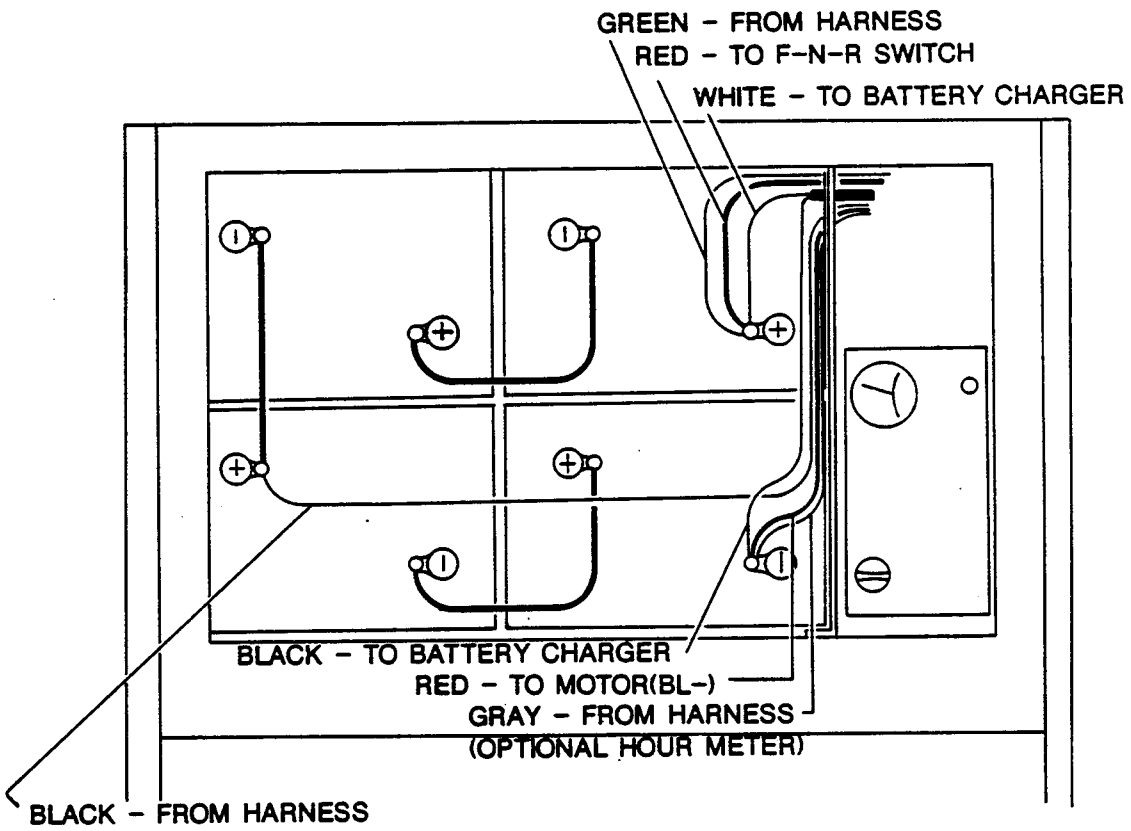

FIG. 10 BATTERY/CHARGER REMOVAL SEQUENCE

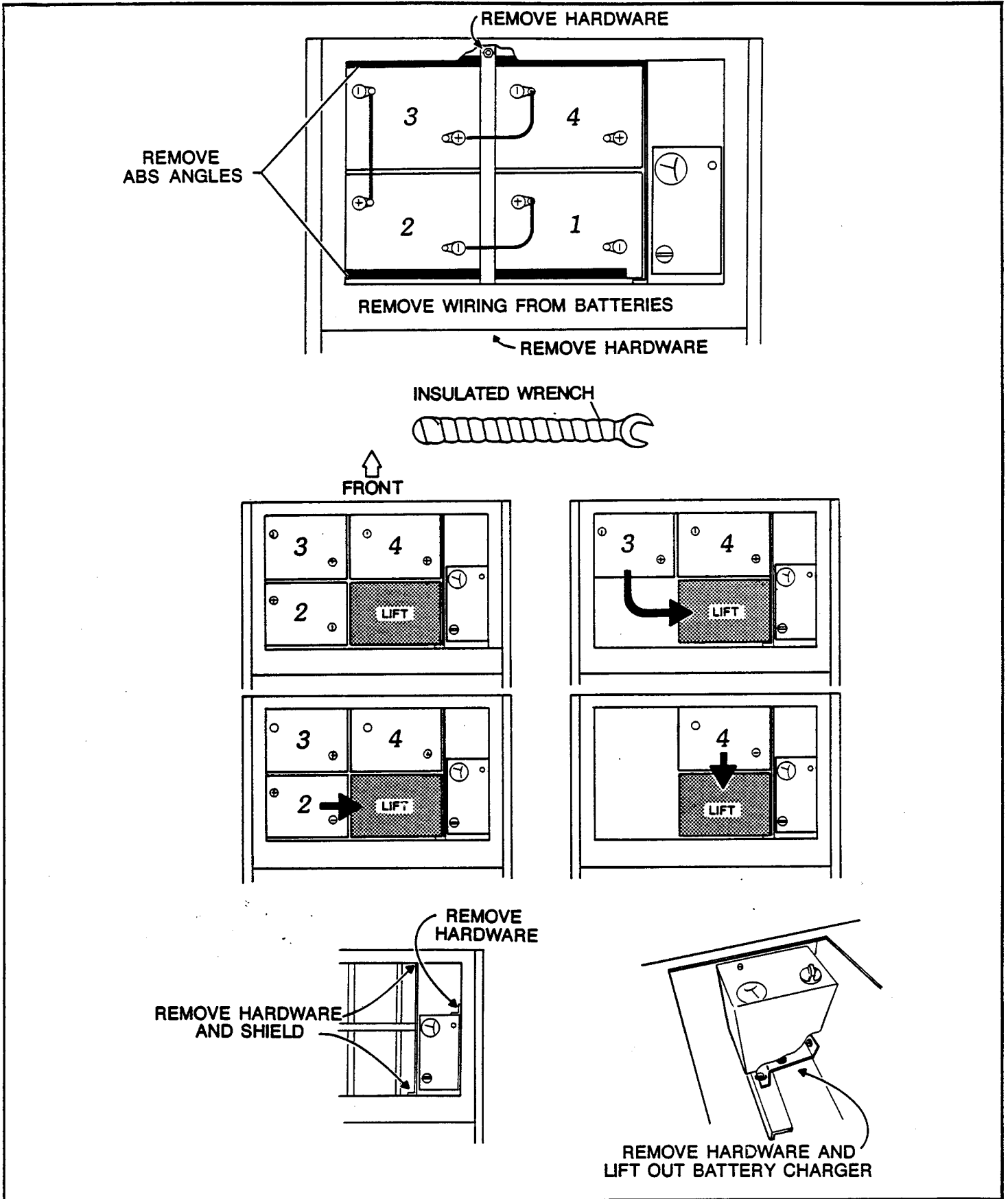

FIG. 10 BATTERY/CHARGER REMOVAL SEQUENCE

when adding water to batteries. E-Z-GO strongly recommends that other water sources **not** be used since impurities can reduce the useful life of the batteries. If it is suspected that a suitable water source other than distilled be available, a water analysis and a consultation with your local representative will indicate if the water is detrimental to battery operation. You may also consult your local telephone company to determine if they use the local water. (The telephone company is a major user of battery powered systems.)

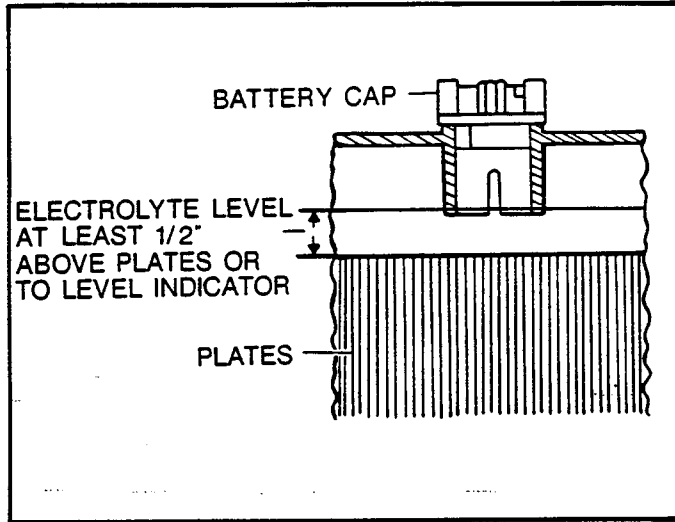

FIG. 11 BATTERY ELECTROLYTE LEVEL

- o Batteries should be recharged after everyday's use.

CAUTION: DO NOT SEND A VEHICLE OUT UNLESS ITS BATTERIES ARE IN A GOOD STATE OF CHARGE. DISCHARGING A BATTERY COMPLETELY BEFORE RECHARGING (DEEP CYCLING) IS DETRIMENTAL TO BATTERY LIFE.

- o Keep batteries clean. Wash batteries with a stiff bristle brush using water and bicarbonate of soda. Rinse with water after cleaning.

WARNING: WEAR GLOVES AND EYE PROTECTION WHEN WORKING WITH BATTERIES. ACID IN THE ELECTROLYTE CAN CAUSE BURNS TO THE EYES, SKIN AND CLOTHING.

- o Batteries should be checked frequently to be sure that they are in a good state of charge. Full charge for a new battery should yield a hydrometer reading of 1.280 specific gravity while an older battery may give a reading of 1.250 specific gravity and still be fully charged.
- o In extended periods of no usage, the batteries should be **fully charged** and stored in an unheated covered area. Check the batteries periodically and recharge if a hydrometer shows a reading of less than 1.220 specific gravity.
- o Before returning batteries to service, perform all of the preceding preventative maintenance.
- o To prevent unnecessary drag on the vehicle which will result in poor performance and a higher amperage draw, inspect for improperly adjusted wheel bearings, dragging brakes, and underinflated tires.

BATTERY INSTALLATION

WARNING: BEFORE PROCEEDING, REMOVE ALL JEWELRY, RINGS, WATCHES, ETC., AND WRAP ALL WRENCHES IN VINYL INSULATING TAPE (FIG. 12) TO ELIMINATE THE POSSIBILITY OF A SHORT CIRCUIT SHOULD THE OPPOSING TERMINALS BE "SHORTED OUT" OR CONTACTED TO THE FRAME. A SHORT CIRCUIT COULD RESULT IN AN EXPLOSION AND SEVERE PERSONAL INJURY.

WARNING: BE SURE THAT THE FORWARD-NEUTRAL-REVERSE SWITCH IS IN THE NEUTRAL POSITION AND THE KEY SWITCH IS IN THE "OFF" POSITION.

Carefully note the manner in which the old set of batteries were installed. (Fig. 10) Pay particular attention to the polarity of the wiring.

Remove the wiring from each battery using an **INSULATED WRENCH** (Fig. 12) and remove the battery hold down. Remove the batteries using a battery removal tool.

TITLE: OPERATION AND MAINTENANCE

WARNING: BATTERIES ARE HEAVY AND CARE SHOULD BE TAKEN WHEN REMOVING THEM. BE CAREFUL TO LIFT BATTERIES WITHOUT TIPPING THEM; ELECTROLYTE MAY BE SPILLED WHICH COULD CAUSE BURNS OR DAMAGE TO VEHICLE AND CLOTHING. SHOULD ANY ELECTROLYTE BE SPILLED, FLUSH THOROUGHLY WITH WATER.

Inspect the battery racks for corrosion and clean if required using a putty knife and a wire brush. Remove **all** corrosion before priming and painting with a corrosion resistant paint.

Inspect all batteries visually for damaged containers, covers or terminals that may have been damaged or broken during transit. Inspect each cell (a dry cell could indicate a possible crack in the battery case).

Inspect all cables and terminations for any defects and replace as required. If they are to be reused, clean in a solution of water and bicarbonate of soda (1 bucket water to 1 cup of bicarbonate of soda). Rinse thoroughly and clean and dry. Remove any remaining corrosion from the wire terminations using a wire brush. Clean the battery terminals with a wire brush until all corrosion is removed.

Install the batteries and the battery hold downs. Tighten the hold down hardware snugly (25-30 in. lbs.) to prevent battery bounce but do not overtighten since the battery case could be distorted.

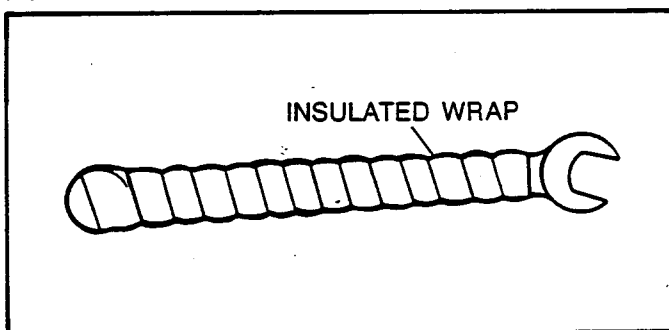

FIG. 12 INSULATED WRENCH

Use an insulated wrench to install the battery wiring and tighten nuts to provide a tight connection between the wire terminations and the battery posts.

Apply a coat of petroleum jelly to the outside of connection to retard corrosion of the joint.

Before the vehicle is put into service for the first time with new batteries, a 12 hour charge is required to charge all batteries to a common level of charge.

When utility vehicles are used for 70-80 minutes or more, the batteries become deeply discharged, which is reflected in a low specific gravity reading.

Batteries in this state of discharge require longer charge cycles to restore their full capacity.

If this lengthy charge time is prematurely terminated because the vehicle is returned to service, the balance of the charge should be made up. This make up or catch up charge should be accomplished at the earliest possible time.

If the recharge is not made up, the batteries become more and more discharged as they are used. When batteries are allowed to remain deeply discharged, their life is shortened.

CHARGING (Fig. 13)

It is most important to follow the following steps when charging batteries.

- o Check that electrolyte covers the plates in **all** cells.
- o Charging must be performed in a well ventilated area.
- o Inspect the charger A. C. plug for loose, bent, arced or dirty contacts.
- o Insert plug fully into receptacle and check that the connection is tight.
- o Be careful not to pull on the A. C. cord or place it in a position where it can be driven over or present a hazard to personnel working in the area.

TURN OFF BEFORE UNPLUGGING

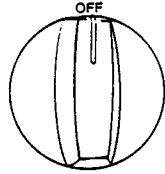

DO !

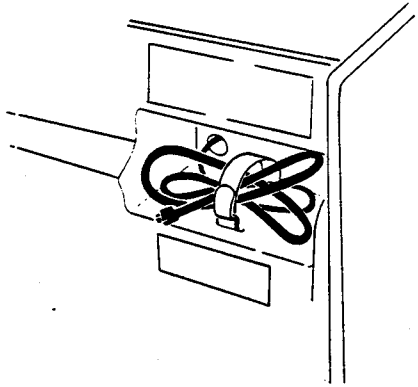

STORE CORD IN PROPER PLACE

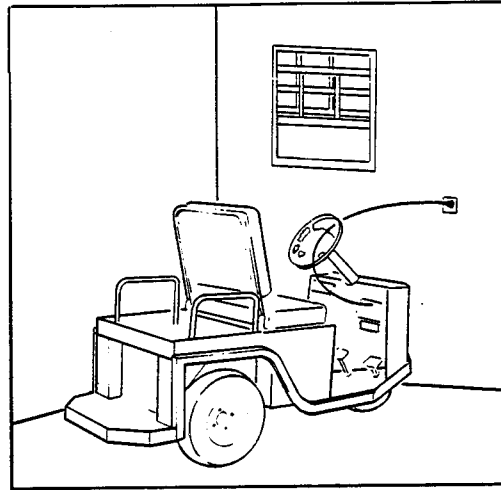

PROVIDE ADEQUATE VENTILATION

DON'T !

DON'T PULL BY THE CORD

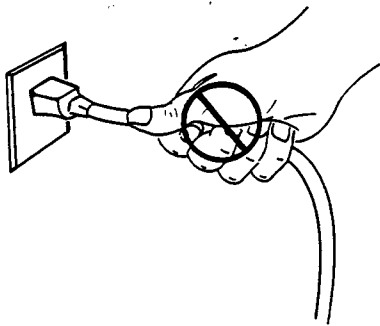

DON'T LEAVE CORD DANGLING

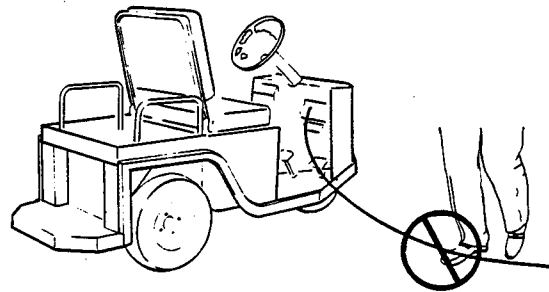

FIG. 13 CHARGING BATTERIES

WARNING: WHEN CONNECTING OR DISCONNECTING THE CHARGER ALWAYS MAKE SURE THAT THE TIMER, ELAPSED TIME INDICATOR, OR POWER SWITCH IS SET IN THE OFF POSITION. IF IT IS NOT, AN ELECTRICAL ARC WILL OCCUR AND MAY CAUSE AN EXPLOSION OR FIRE.

Observe the ambient temperature in the charging area. A battery requires a longer charge time than normal when the ambient temperature falls below 60° F. The time required increases as the ambient temperature decreases.

A. C. LINE VOLTAGE

The battery charger's initial output is directly proportional to the input voltage. If a problem is encountered with several vehicles that indicates an insufficient initial (start) charge, it is suggested that the batteries be tested, and if found satisfactory, then the input A. C. voltage should be checked by the power company and their recommendations be followed.

ADDING WATER

The electrolyte in the vehicle's batteries is a solution of sulfuric acid and water. Some of the water portion of this solution evaporates or is lost in the charging cycle but the acid is retained. In the life of a battery, it is only necessary to replenish water and not the acid.

WARNING: IF A CONSIDERABLE AMOUNT OF BATTERY ELECTROLYTE IS SPILLED, IT MAY BE REPLACED. BE SURE TO OBSERVE ALL PROCEDURES, CAUTIONS, AND WARNINGS PROVIDED BY THE ELECTROLYTE MANUFACTURER.

When replenishing water, use only distilled water. See section on Preventative Maintenance.

In the life of an average battery, the water usage will be approximately 2 1/2 times the original electrolyte quantity, or approximately 16 quarts.

CAUTION: USE OF NON DISTILLED WATER CONTAINING VARIOUS MINERALS BECOMES SIGNIFICANT IN THIS QUANTITY AND WILL HAVE A DETRIMENTAL EFFECT ON THE LIFE OF THE BATTERY.

WATER LEVEL (Fig. 14)

Add water to the indicator ring if equipped or to 1/2" above the top of the separators. Filling above this level will cause the loss of electrolyte during the charging cycle. The charging cycle causes bubbles to occur which will cause the electrolyte to fill the cavity above the plates. If the electrolyte is over-filled, the gassing will force a portion of the electrolyte out through the vent holes in the vent caps. The result of this electrolyte loss will additionally result in corrosion of the wire and connections and the corrosion of the battery support members.

CAUTION: BEFORE CHARGING, BE SURE THAT THE ELECTROLYTE IS ABOVE THE SEPARATORS. NEVER ALLOW THE ELECTROLYTE TO FALL BELOW THE TOP OF THE PLATES SINCE PERMANENT DAMAGE CAN RESULT TO THE UNCOVERED PORTION OF THE PLATES.

NOTE: It is recommended that any additional water required be added at the end of the charging cycle.

E-Z-GO recommends that all vent caps be removed and immersed in a clean container of water while watering the batteries. This will prevent loss of the caps and dilute any acid residue that could result in burned fingers. After replacing vent caps, rinse off batteries with a hose to eliminate any spilled electrolyte that may have been splashed during the watering operation.

CLEANING

A coating of acid impregnated dirt on the top surface of a battery will create an electrical path between the terminals of the battery. This electrical path will cause a "current leakage" which will both reduce the operating efficiency of the battery and reduce its useful life.

CAUTION: BE SURE ALL VENT CAPS ARE SECURELY IN PLACE BEFORE CLEANING BATTERIES. THIS WILL PREVENT CONTAMINANTS FROM ENTERING BATTERIES.

WARNING: USE EYE PROTECTION AND GLOVES DURING THE FOLLOWING CLEANING OPERATION.

Wash with a hose and remove any remaining foreign matter using a stiff bristle brush and a solution of water and bicarbonate of soda (1 cup of bicarbonate of soda to 1 bucket, approximately 8 quarts, of water). Hose off batteries after cleaning.

TESTING BATTERIES

What To Check: If a vehicle fails to perform satisfactorily and it is suspected there is a battery failure, each battery should first be checked individually and then all batteries in the vehicle should be checked as a set.

Test With Hydrometer: Using a battery hydrometer, test each battery individually, comparing the three cell readings of each battery. If the variation between the highest and lowest cell readings in any one battery is .050 (50 gravity points) or more, there is reason to suspect a weak or failing cell. This test is best accomplished with the batteries in a **partially** discharged state; after the vehicle has been used for at least 15-20 minutes.

Instructions For Using Hydrometer: (Fig. 15)

1. Draw the minimum of electrolyte into the test tube to permit the float to float freely without contacting the top or bottom of the test tube.
2. Hold hydrometer in a vertical position and take a reading at your eye level.
3. Always correct hydrometer Specific Gravity reading to 80° F. For each ten degrees temperature above 80° F, add 4 points to reading. Example: 90° F 1.250 Sp. Gr. = 1.254. For each ten degrees below 80° F, subtract 4 points from reading. Example: 70° F 1.250 Sp. Gr. = 1.246.
4. Test each cell; record readings (corrected to 80° F). A variation of 50 points between any two cell readings (example 1.250 = 1.200) indicates a defect in the low reading cells.

VOLTMETER CHECK

If the voltage of **each** cell cannot be measured, test the terminal voltage of each battery (if a set of batteries is being checked). Compare the voltage of the batteries against one another. If the battery voltage readings vary

by 0.5 volts or more, there is probably a weak or failing battery. As stated under "Hydrometer Check", the Voltmeter check is more effective if the batteries are partially charged.

If the batteries in the vehicle have been on charge and are to be tested with a voltmeter, drive the vehicle around for approximately 30 seconds, then let it stand idle for three or more minutes before testing. This stabilizes the voltage. In this instance, it removes a "surface charge" from the plates which would give a false high voltage reading.

LOAD TEST

This test is designed to simulate the demands imposed on batteries supplying power to electric vehicles.

Batteries fully charged and with the electrolyte temperature @ 80°F ± 5°F (26.5°C ± 3°C) are discharged at the constant rate specified for the type battery being tested to a terminal voltage equivalent to 1.75 volts per cell. The discharge time in minutes is the battery capacity. The full charge electrolyte specific gravity is to be the same as specified by the battery manufacturer.

Electric vehicle batteries shall be tested as indicated above at a rate of 75 ± 1 ampere. There are load testers on the market that are capable of testing batteries in the vehicle.

If the Hydrometer or Voltmeter check indicates a battery, or one battery in a set of batteries is failing, fully charge it and conduct the above Load Test. Record the discharge time in minutes for the cell voltage to reach 1.75 volts (5.25 volts for a 6 volt battery). A battery which delivers 50% or less of its rated capacity in minutes should be replaced.

The life of an electric vehicle battery is determined not only by the number of cycles (a discharge and a recharge) it receives but also by the depth of each cycle. Suppose batteries are used to operate a vehicle 35-40 minutes per day. Let us call that one life cycle. If they are used for 70-80 minutes, this is a much deeper discharge and would be equivalent to approximately three life cycles. A battery used 70-80 minutes per day will have a life span approximately one-third that of one used 35-40 minutes per day.

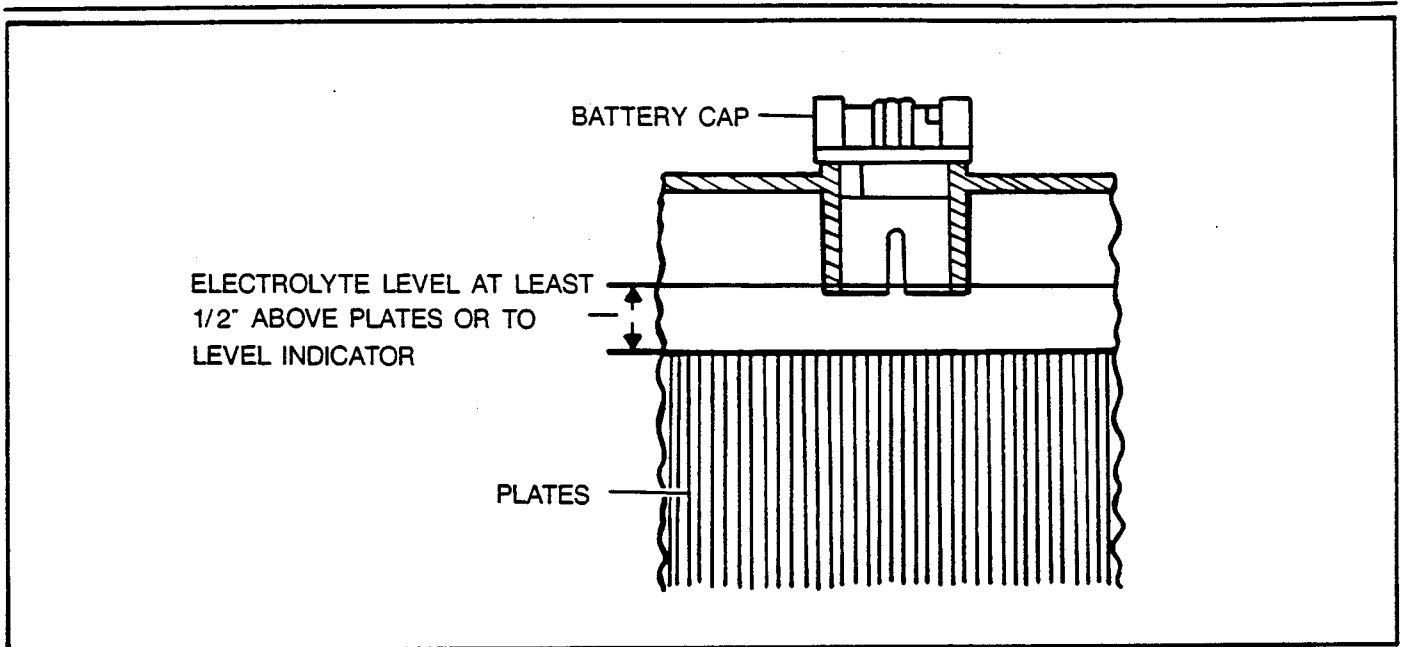

FIG. 14 BATTERY ELECTROLYTE LEVEL

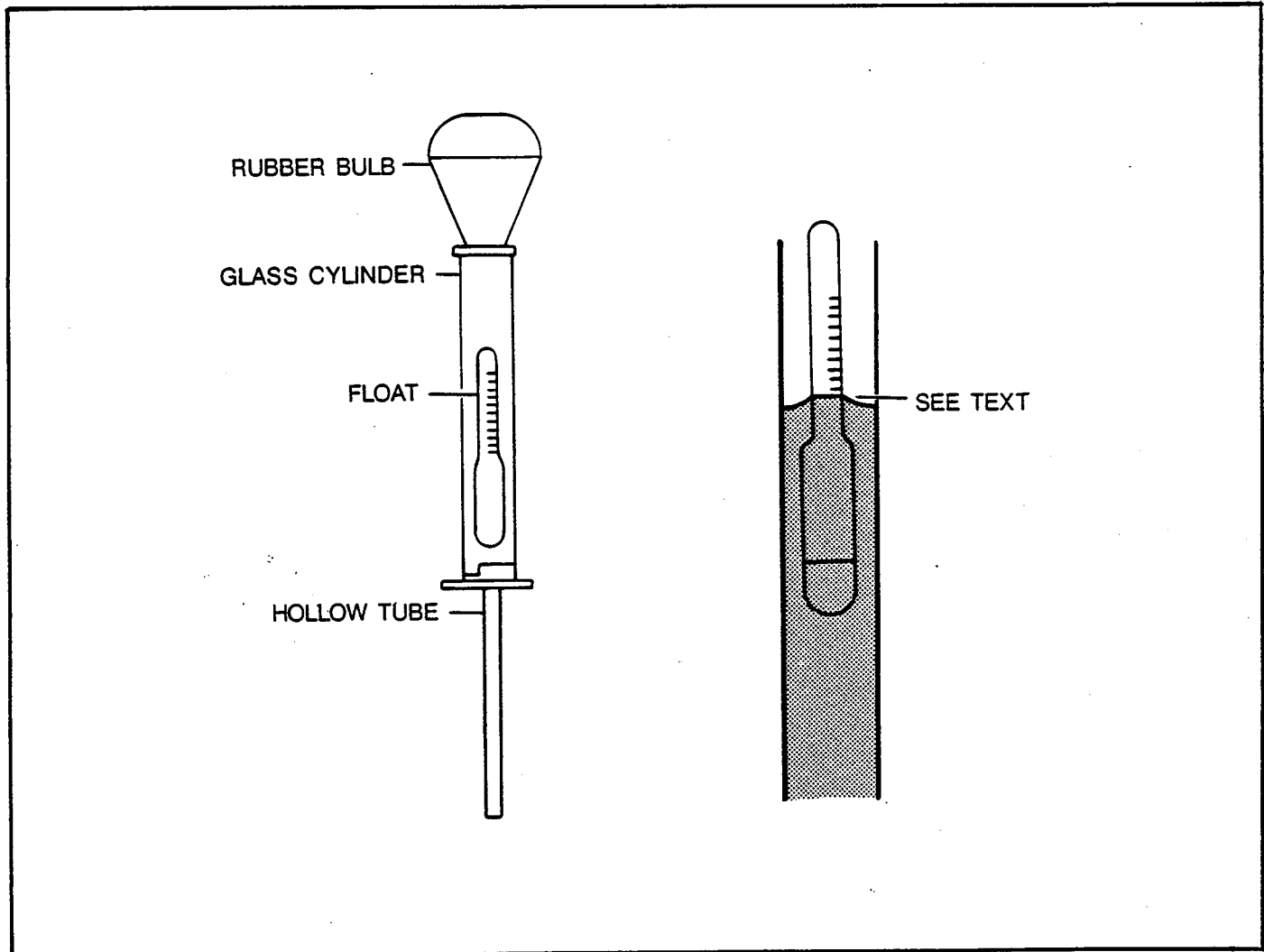

FIG. 15 USING HYDROMETER

GENERAL, BATTERY CHARGER

The battery charger is semi-automatic and is designed specifically for charging electric vehicle batteries.

The charger type is known as a ferro-resonant. The term ferro-resonant is applied to a charger that starts the charge at a relatively high rate of charge and continuously reduces the rate as the battery or batteries become nearer the full charge condition.

CHARGER POWER REQUIREMENTS (Fig. 16)

Each charger requires an input of a dedicated 110-120 Volt A.C. 60 cycle 15 Amp circuit, equipped with standard three prong, NEMA 15-5R receptacles.

See paragraph in BATTERIES SECTION of this manual for symptoms that may indicate a low input voltage (A.C.) condition.

The power (A.C.) cord is equipped with a standard three prong U. L. listed grounded type plug. Electrical outlet receptacles installed for use at the battery charging locations must be of the three prong grounded type (NEMA 15-5R), which will ground the charger and vehicle to eliminate any electrical hazard.

After charging, coil the A.C. cord and secure in the dash storage area using the velcro strap provided.

WARNING: AN UNGROUNDED ELECTRICAL DEVICE MAY BECOME A PHYSICAL HAZARD THAT COULD RESULT IN AN ELECTRICAL SHOCK OR ELECTROCUTION.

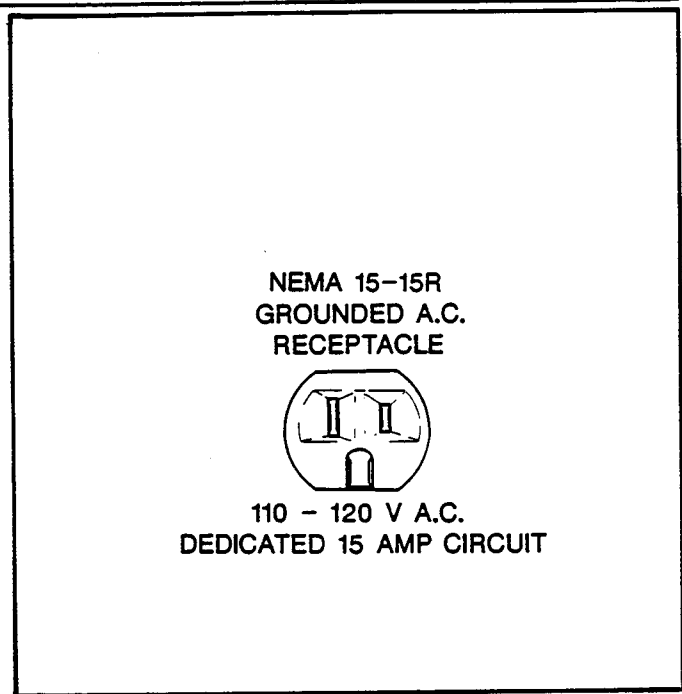

FIG. 16 CHARGER PLUG

WARNING: WHEN CONNECTING OR DISCONNECTING THE CHARGER ALWAYS MAKE SURE THAT THE TIMER, ELAPSED TIME INDICATOR, OR POWER SWITCH IS SET IN THE OFF POSITION. IF IT IS NOT, AN ELECTRICAL ARC WILL OCCUR AND MAY CAUSE AN EXPLOSION OR FIRE.

Semi-annually (or more often in a dusty environment) the charger should be removed from the vehicle, the cover removed and the fan and vents cleaned with a dry brush. (Fig. 10)

OPERATION AND MAINTENANCE

SECTION: ELECTRICAL – SOLID STATE SPEED CONTROL

GENERAL (FIG. 17)

There are two distinct circuits used in the operation of an electric vehicle. These circuits are the *CONTROL* and the *POWER* circuits.

CONTROL CIRCUIT

The control circuit may be identified by the light gauge wire used. The control circuit components consist of the key switch, the solenoid, a reverse warning device and two micro switches. Micro switch 2 (MS-2) is actuated by the forward-neutral-reverse switch and micro switch 3 (MS-3) is actuated by movement of the potentiometer lever which is moved by the accelerator linkage.

FORWARD OPERATION

With the key switch in the 'ON' position and the F-N-R switch in the 'FORWARD' (F) position, micro switch 2 (MS-2) is closed which provides an electrical path to accelerator micro switch. Depressing the accelerator pedal moves the lever of the potentiometer from the 'OFF' position and also activates micro switch 3 (MS-3). The closure of micro switch 3 (MS-3) completes the control circuit and activates the coils of the solenoid. This causes the solenoid contacts to close which in turn activates the power circuit.

REVERSE WARNING OPERATION

The reverse operation is identical to forward operation except that a reverse warning device is activated by the forward-neutral-reverse switch that is placed in the 'REVERSE' (R) position which activates micro switch MS-1. This warning device is in continuous operation while the F-N-R switch is in the 'REVERSE' (R) position.

POWER CIRCUIT

With the control circuit activated, the solenoid contacts are closed. Power is applied to the power circuit. Depressing the accelerator pedal moves the lever of the potentiometer which increases the resistance from 0 – 5000 ohms. The control module uses solid state circuitry to supply the appropriate power required through the F-N-R switch which directs this power through the armature and field windings of the motor to control the speed of the vehicle.

FEATURES AND BENEFITS OF THE SOLID STATE SPEED CONTROL

SMOOTH STEPLESS OPERATION

1. The E-Z-GO Solid State speed controller gives the operator stepless control of vehicle's drive motor speed. This is possible through the use of electronic control techniques by which the power delivered to the motor can be smoothly varied from fully off to fully on. There are no speed steps or increments.

A high power semiconductor switch consisting of an array of paralleled power MOSFET transistors, controls the current in the motor windings. The transistors are connected in series with the battery and the motor. The transistors are turned on and off at the rate of 15,000 times per second by the control circuitry, while the ratio of the on and off times is varied in response to the input demanded by the position of the accelerator pedal. This technique is called pulse width modulation. When the transistors are on, the current through the motor builds up, storing energy in the motor's magnetic field. When the transistors turn off, this stored energy causes the motor current to continue to flow through the free wheel diode. The motor current ramps up and down as the switch turns on and off, the average current (which determines the motor torque) being controlled by the ratio of the on and off times. In this way, smooth, stepless control of the power delivered to the motor is achieved with very low power loss in the control components.

CURRENT MULTIPLICATION

2. One of the most intriguing features and benefits of the E-Z-GO Solid State speed controller is the fact that during acceleration, or reduced speed operation, it allows more current to flow into the motor than flows out of the battery. This is possible because the controller acts like a D.C. transformer i.e., it takes in high voltage (the full battery voltage) and low current, and puts out low voltage and high current. Thus for these conditions the battery only has to supply a fraction of the current required by a resistor type controller in which the battery current and

ELECTRICAL - SOLID STATE SPEED CONTROL

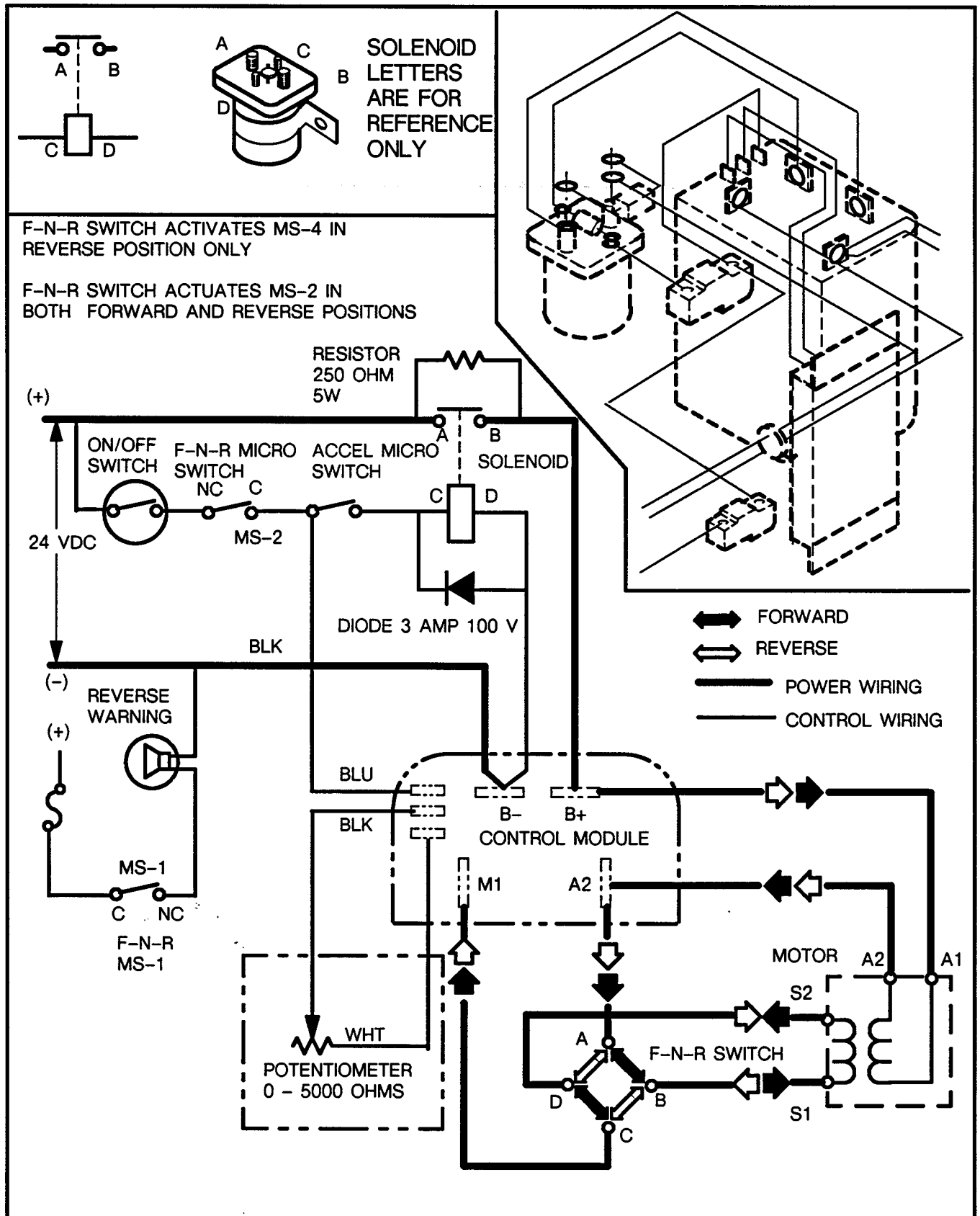

FIG. 17 WIRING DIAGRAM

ELECTRICAL – SOLID STATE SPEED CONTROL

motor current are always equal. The result is a dramatic improvement in the vehicle's efficiency; this gives greater driving range per battery charge.

CURRENT LIMITING

3. Another feature of the E-Z-GO Solid State controllers is their ability to limit the motor current to a preset maximum. This current limit feature protects the controller from damage which might result if the current were limited only by the motor demand. The current limit feature is also very important to the rest of the system because it reduces the stresses placed on the motor, drive train and batteries. Motor and battery efficiency and service life are both improved by eliminating high current surges during vehicle acceleration. This also saves wear and tear on vehicle transmissions and drive trains and in some cases, the terrain that the vehicle rides on (e.g., fairways and greens).

UNDER VOLTAGE CUTBACK

4. The controller must have a means of preventing operation at very low battery voltages. This is because the control circuitry requires some minimum voltage to function properly. For this reason, the controller is designed so that its output is gradually reduced if the battery voltage falls below a certain level; for the standard 24 volt models this happens at 16 volts. By reducing the output to the motor, the battery voltage can recover and an equilibrium is established in which the battery is allowed to supply as much current as it can without falling below 16 volts.

THERMAL PROTECTION

5. The design of these transistorized motor controllers has placed a great deal of emphasis on thermal management and in normal operation they barely get warm. If, however, the controller is undersized for its application or otherwise overloaded, overheating may occur. If the internal temperature of the controller exceeds 165 degrees Fahrenheit, the current limit will be reduced to approximately one half of its rated value. This will generally allow vehicle operation

at a reduced performance level, to allow maneuvering out of the way and stopping in a good place. When the controller cools down, full current limit and performance will automatically return.

RUNAWAY PROTECTION

6. These controllers have a feature which shuts off the output in the event of an 'open' circuit fault in the potentiometer or its wiring which could otherwise result in uncontrolled full speed operation. The standard throttle configuration is a $5000 \pm 10\%$ ohm, 2 wire potentiometer going from zero ohms for full off to 5000 ohms for full on. Broken potentiometer wiring, connectors or potentiometers which fail open would normally give a full on signal. The controller detects any throttle inputs of more than 7000 ohms as a fault and shuts off the output preventing a runaway. The controller will return to normal operation when the fault is repaired.

HIGH PEDAL PROTECTION (FIG. 18)

7. The E-Z-GO Solid State controller has circuitry to sense a 'high' (depressed) accelerator pedal at the time the controller is turned on and inhibit the output until the pedal is released and re-applied. This safety feature (also called Neutral Start or High Pedal Disable) prevents the vehicle from being turned on with the throttle depressed, requiring the operator to start smoothly from zero throttle. It also protects against sudden starts caused by problems in the throttle linkage (e.g., bent parts, broken return spring etc.) which might give a partial or full throttle signal to the controller even with the pedal released.

SERVICEABILITY

8. The design philosophy of the E-Z-GO Solid State controllers has been to make simple, easily installed controllers requiring no user adjustments or modifications. Experience has shown that the electronic components are very reliable and that many problems are caused by the effects of contamination (especially water and battery acid). Accordingly, these units are sealed into an electrically isolated aluminum ex-

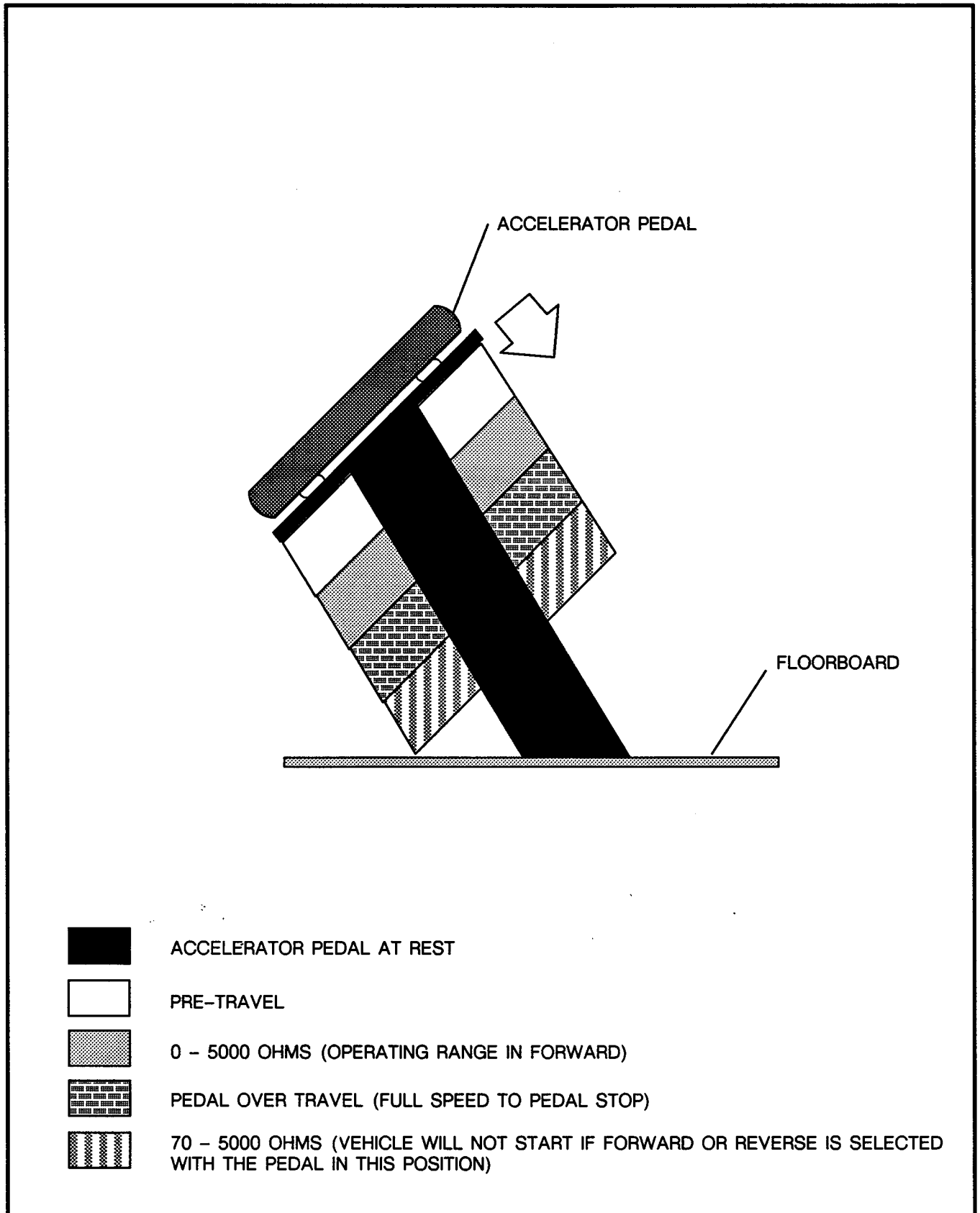

FIG. 18 ACCELERATOR POSITIONS

ELECTRICAL – SOLID STATE SPEED CONTROL

trusion and are not field serviceable. The controllers are, however, rebuildable at the factory.

TROUBLE-SHOOTING VEHICLE WIRING (FIG. 19), (FIG. 20), (FIG. 22)

Tools Required: Qty.

Volt Ohm Meter 1

If the car fails to operate or operates poorly, the following test sequence should be followed.



WARNING

TO PREVENT THE VEHICLE FROM INADVERTENTLY ACCELERATING, WHICH COULD CAUSE BODILY INJURY, THE VEHICLE MUST BE LIFTED TO RAISE BOTH DRIVE WHEELS ABOVE THE GROUND.

Raise the vehicle before proceeding.

Examine all of the wiring of the controller to assure that all wires are without physical damage or corrosion. Check the routing of all wiring and the tightness of each connection. Repair or replace any suspect wires or connections.

To test the control circuit, turn the key switch to the 'ON' position. Set the volt meter to the 50 VDC range. Touch the black probe to the negative (-) contact of the vehicle D.C. receptacle and the red (+) probe to the positive (+) contact of the vehicle D.C. receptacle. (FIG. 20)

A meter reading of 24 VDC ± 5 V indicates the batteries are satisfactory. A reading of below 24 VDC ± 5 V indicates that one or all batteries are defective or are in need of charging (see Batteries Section for testing procedures). No reading indicates an 'open' condition and the power transmission circuit should be inspected for a broken or disconnected conductor.

With the F-N-R switch in the 'FORWARD' (F) position, remove the red (+) probe from the positive contact of the receptacle and relocate it to the positive (+) terminal of the solenoid. A meter reading of 24 VDC ± 5 V will indicate that the heavy gauge wire (BL+) and terminations between the battery and solenoid positive (+) terminal are in good condition.

TROUBLE-SHOOTING SOLID STATE SPEED CONTROLLER (FIG. 17), (FIG. 21), (FIG. 22)

GENERAL

The following procedures will assist in the trouble-shooting and repair or adjustment of the E-Z-GO solid state speed controllers in an efficient and timely manner.

No procedure can cover every situation, therefore this procedure should be used in conjunction with good repair practices.



WARNING

BEFORE ATTEMPTING TO TROUBLE-SHOOT OR REPAIR THE EQUIPMENT BE SURE THAT THOSE WORKING ON OR AROUND THE EQUIPMENT CANNOT BE INJURED. REFER TO THE APPROPRIATE PARAGRAPHS IN SECTION 'B' FOR THE CORRECT PROCEDURE FOR RAISING BOTH OF THE VEHICLES DRIVE WHEELS. OBSERVE ALL WARNINGS PERTAINING TO SAFE PRACTICES WHEN WORKING ON AN ELECTRIC VEHICLE. ALWAYS WEAR APPROVED EYE PROTECTION.

Tools Required: Qty.

Volt Ohm Meter 1
Wrench, open end, 7/16" 1
Wrench, open end, 1/2" 1
Wrench, open end, 3/8" 1

No special tools are required to install, remove or adjust the unit. Good quality tools are required and vice grips, pliers or adjustable wrenches should not be used.

The use of a Volt Ohm Meter (V.O.M.) is mandatory to perform trouble-shooting on the solid state speed controller. When selecting a V.O.M., either an analog (needle type) or a digital type is acceptable, although it is easier to determine small voltage and resistance changes with a digital meter. You do not need to purchase the most expensive available but it should be capable of accurately measuring both voltage and resistance. If an analog meter is selected it should have a scale that is large enough to be easily and accurately read. The meter will be reading voltages from 1 to 50 and resistances from 0 to 10,000 ohms. Look at the the DC voltage selector and select a meter that permits voltage selection

ELECTRICAL - SOLID STATE SPEED CONTROL

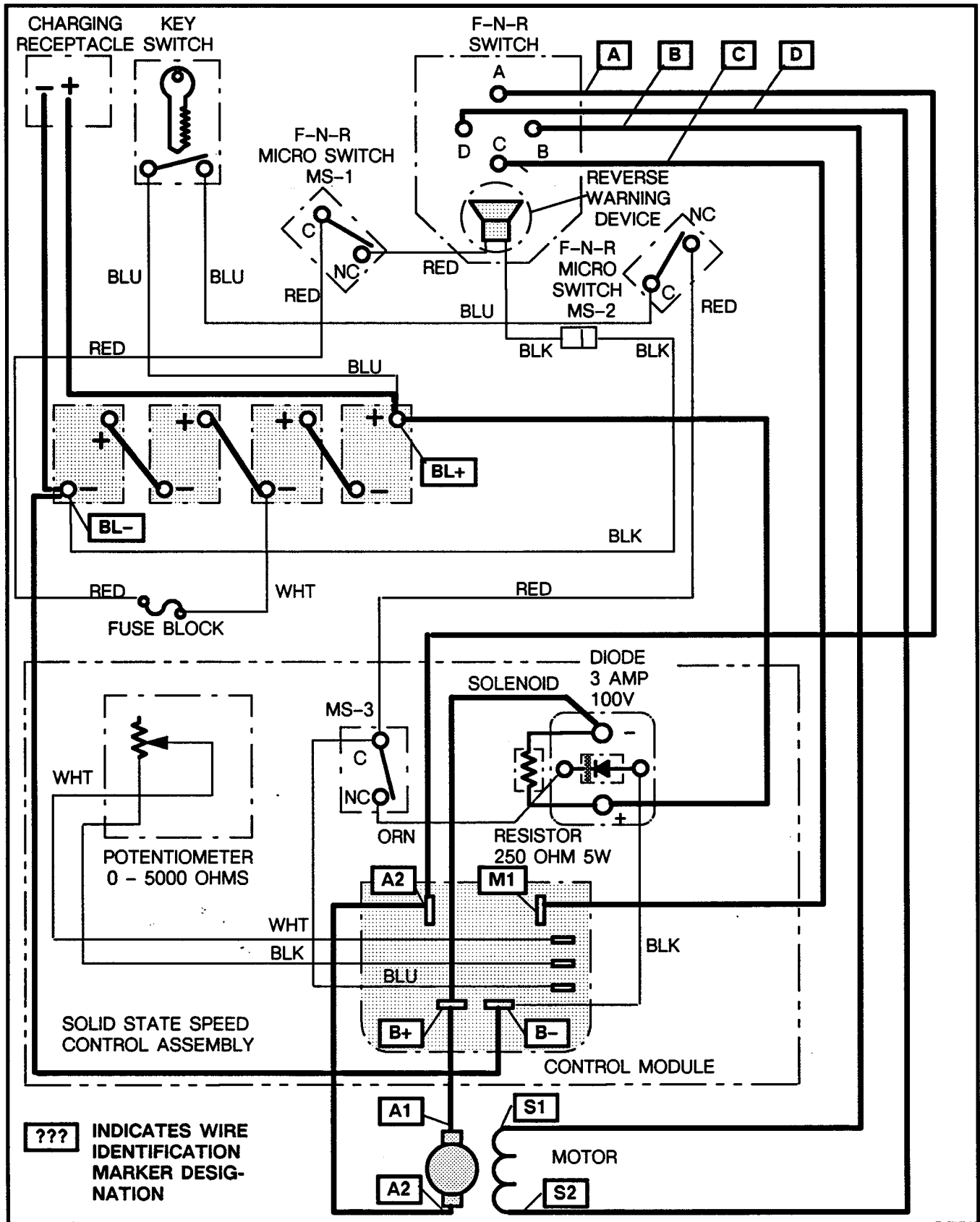
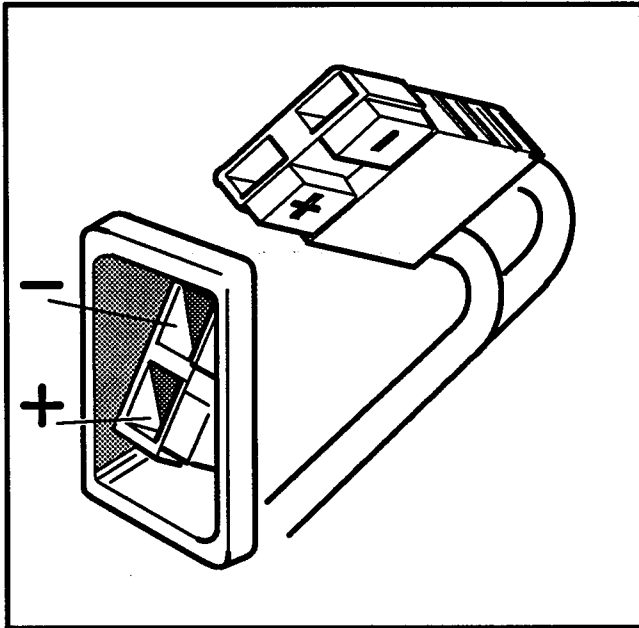

FIG. 19 POWER WIRING DIAGRAM



**FIG. 20 CHARGING RECEPTACLE
(VIEWED FROM FRONT)**

that is most applicable to your needs. Remember that reading 6 volts on a 50 volt meter scale would be difficult. The same problem exists when reading resistance (ohms). Select a meter with scales that are appropriate for the readings required. A meter that can easily be misinterpreted can cost many hours of wasted time looking for problems that do not exist or overlooking genuine problems. It does not matter if you choose analog or digital, just be sure that the meter is reliable and accurate. Most important however is to be sure that you know how to use it efficiently.

TROUBLE-SHOOTING (FIG. 17), (FIG. 18), (FIG. 21), (FIG. 22)

Use common sense and the following step by step chart when trouble-shooting the entire accelerator and solid state controller system.

1. Verify that adequate battery voltage is present to operate the vehicle. Battery voltage should be 24VDC \pm 5 V after the surface charge is removed.
2. Examine all of the wiring to assure that all wires are without physical damage or corrosion. Check the routing of all wiring and the tightness of each connection. Repair or replace any suspect wires or connections. (FIG. 22)

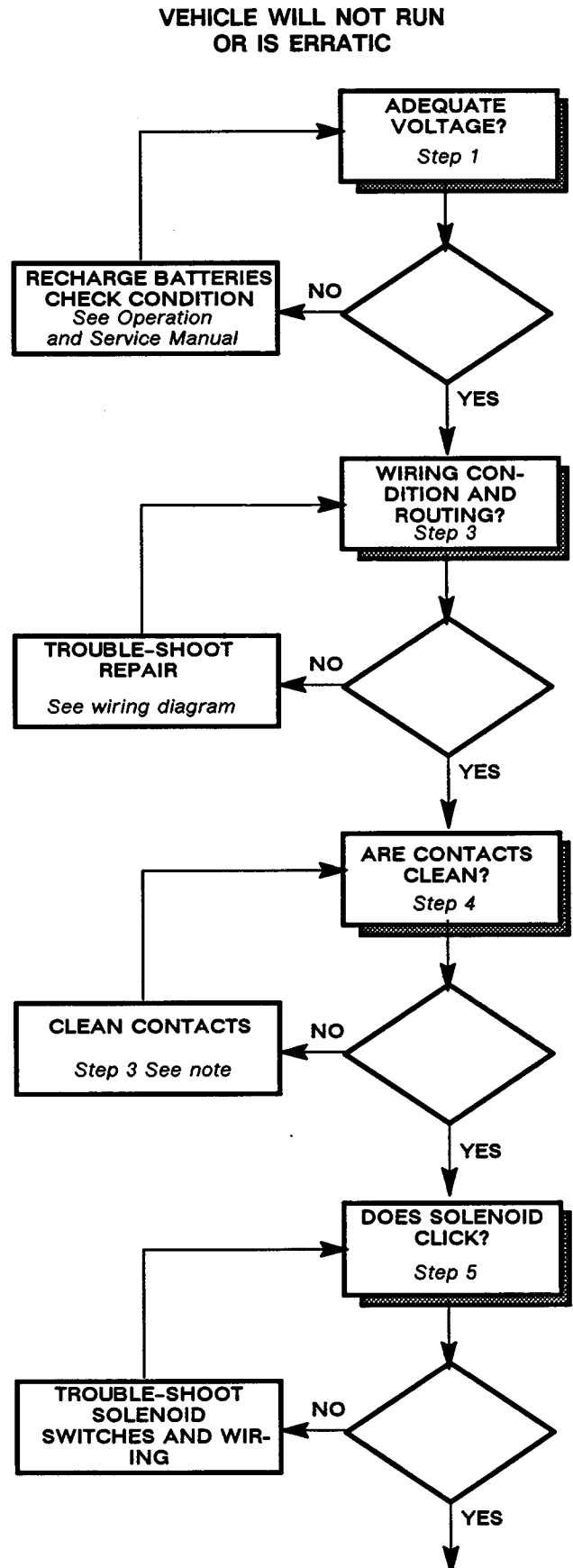

ELECTRICAL – SOLID STATE SPEED CONTROL

3. Inspect the male 'push on' contacts at the control unit and be sure that they and the areas around them are free of corrosion. (FIG. 17)

NOTE

Use radio and TV tuner cleaner applied with a 'Q tip' or a small brush. **Do not use solvents that could attack the plastic sealant.** Mild soap and water applied with a soft brush (tooth brush) rinsed with clear water and thoroughly dried is very effective.

4. Remove the 'push on' connection from the control unit (Blue wire from the micro switch to the control unit). Place the F-N-R switch in the 'FORWARD' (F) position, turn the key switch to 'ON' and slowly depress the accelerator pedal. The solenoid should make an audible 'click'. If there is an audible 'click' go to step 6. If there is no 'click' the fault is in the solenoid coil, micro switch, key switch or wiring.
5. With the V.O.M. (volt ohm meter) adjusted to the correct scale, connect the (Black -) probe to the (B-) terminal at the battery set. Connect the (Red +) probe to the female contact of the wire that was removed in step 4. With the key switch in the 'ON' position battery voltage should be indicated. If battery voltage is not indicated move the (Red +) probe to each component working towards the positive side of the battery until the defective component is found. Example: From wire to accelerator micro switch to key switch to (+) terminal of battery. If battery voltage is present at the female connection of the wire removed in step 4 and the solenoid does not 'click' the fault is in the solenoid coil windings and the solenoid must be replaced.
6. With the V.O.M. meter adjusted to the correct scale and with the top 'push on' connector removed, place the F-N-R switch in the 'FORWARD' (F) position. Connect the (Black -) probe to the (Red -) terminal at the battery set. Connect the (Red +) probe to the large solenoid contact connected to the positive side of the battery set and verify that battery voltage is present. Move the (Red +) probe to the other large contact, the meter should indicate approximately 5 V less than battery voltage indicating that the resistor is in good condition. No voltage drop indicates a welded solenoid that must be replaced. A voltage drop value greater

than '1' indicates a poor resistor that must be replaced. Depress the accelerator pedal several times to activate the solenoid and observe the meter. No meter movement or erratic movement indicates poor or defective solenoid which must be replaced. Full battery voltage indicates that the system is functioning properly.

7. At the control unit remove, the two wires with female 'push on' connectors coming from the potentiometer. With the VOM adjusted to the correct Ohms scale attach each probe to the two wires from the potentiometer. With the accelerator pedal in the released position the meter must indicate '0' ohms and continue to indicate '0' through at least 1/2" of downward pedal movement. Slowly depress the accelerator pedal and observe the meter. The meter should rise smoothly to $4.75\text{ K} \pm 250$ ohms. When the meter indicates $4.75\text{ K} \pm 250$ ohms the pedal should not be fully depressed. (Approximately 1/4" of pedal travel should remain after the $4.75\text{ K} \pm 250$ ohm reading). If correct readings are not achieved, check the potentiometers activating linkage. With the accelerator in the released position insert a spacer (dime) between the arm and the top stop. The potentiometer activating lever should just retain the dime (FIG. 21). Should the potentiometer activating lever not properly contact the top stop, remove the connecting linkage and adjust by lengthening or shortening the linkage (FIG. 21). With the accelerator in the released position the potentiometer activating lever should just contact the upper stop with a spacer (dime) installed.
8. Depress the accelerator pedal. The micro switch attached to the potentiometer should activate as near to the '0' ohms position as possible.

NOTE

If the micro switch activation takes place at 50 ohms or higher the high pedal protection circuit will be activated which will cause the unit to malfunction.

9. Remove one of the V.O.M. probes and touch to the metal housing of the potentiometer. The meter should read infinity (∞), if it does not, replace the potentiometer.

ELECTRICAL - SOLID STATE SPEED CONTROL

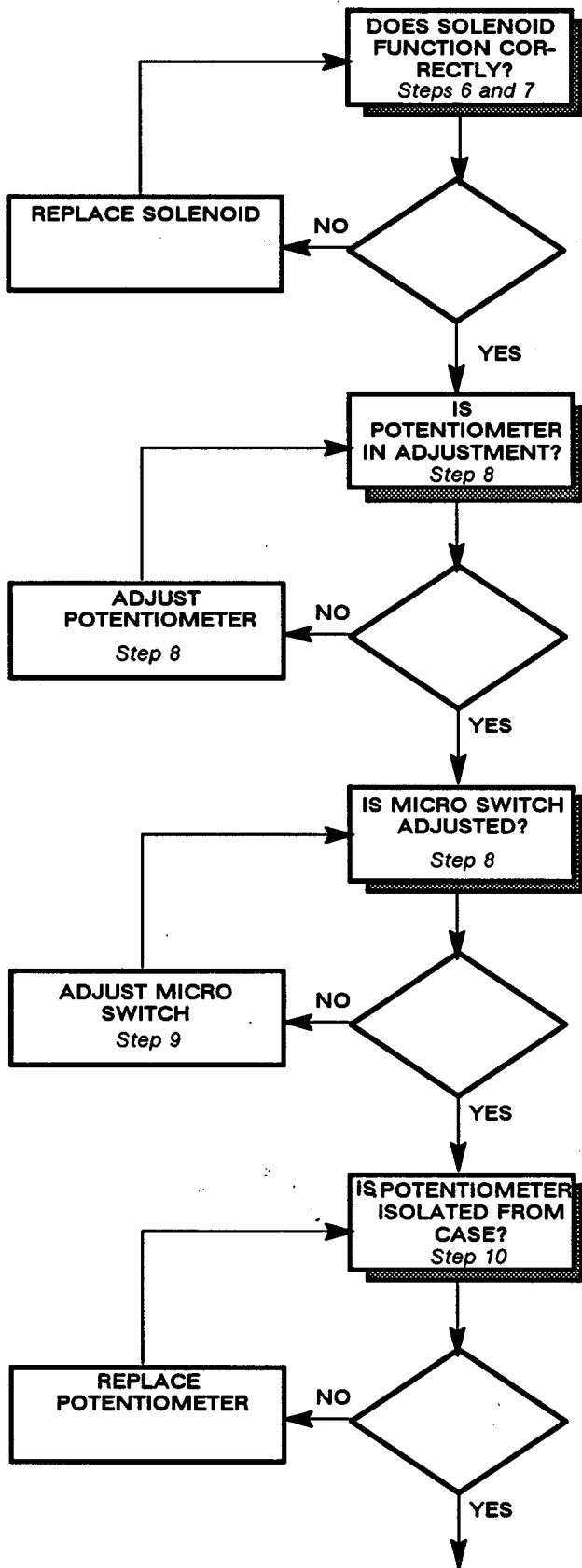

10. Reconnect the wiring. If the vehicle does not operate correctly check the F-N-R switch, the motor and use a Volt Meter wired between (B +) and (M-) which should indicate between '0' and battery voltage when the accelerator pedal is operated. If all of the previous checks indicate that the vehicle is in good operating condition, the control module must be replaced with a new one that is known to be good.

REVERSE WARNING DEVICE (FIG. 23)

The completion of the preceding trouble-shooting procedure will have checked all wiring and components in the control circuit.

The reverse warning device does not affect the operation of the vehicle, however, E-Z-GO strongly recommends that its operation be checked and maintained since the correct functioning of this safety device may prevent an accident.

The warning device (FIG. 23) should sound whenever the F-N-R switch is in the 'REVERSE' (R) position. Should the warning device fail to sound, the following procedure should be used to trouble-shoot the circuit.

Set the Volt Meter to the 15 VDC range, check that the key switch is 'ON' and the F-N-R switch is in the 'REVERSE' (R) position. Locate the black probe (-) in the negative side of the vehicle receptacle (FIG. 20) and place the red (+) probe to the terminal on micro switch 2 (MS-2) with the white wire closest to the F-N-R switch. A meter reading of 12 VDC indicates that the white wire between the positive (+) terminal of the front right battery and the micro switch 2 (MS-2) is in good condition.

Separate the connection in the black wire from the warning device to the battery. Place the red probe (+) on the terminal of the black wire attached to the battery. A meter reading of 12 volts indicates that the black wire from the battery is in good condition. Rejoin the connection.

Locate the red (+) probe on the other terminal of micro switch 2 (MS-2). A meter reading of 12 VDC will indicate that the micro switch 2 (MS-2) is in good condition and that the warning device must be replaced.

ELECTRICAL – SOLID STATE SPEED CONTROL

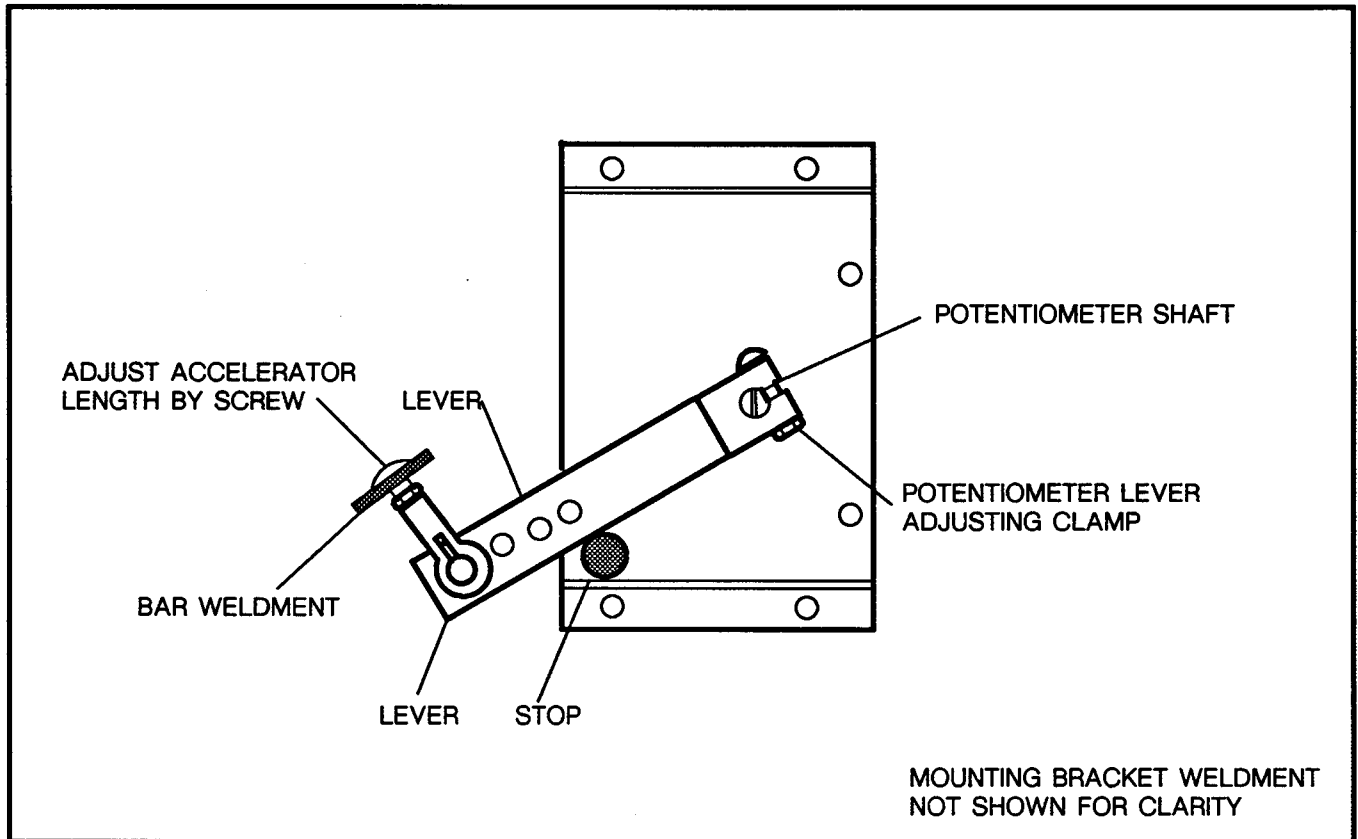

FIG. 21 ACCELERATOR ADJUSTMENTS

POWER CIRCUIT (FIG. 24)

Tools Required:	Qty.
Volt Ohm Meter	1

IF THE VEHICLE DOES NOT RUN:



WARNING

TO PREVENT THE VEHICLE FROM INADVERTENTLY ACCELERATING, WHICH COULD CAUSE BODILY INJURY, THE VEHICLE MUST BE LIFTED TO RAISE BOTH DRIVE WHEELS ABOVE THE GROUND.

Raise the vehicle before proceeding.

Place key switch in the 'ON' position and the F-N-R switch to the 'FORWARD' (F) position.

Set the Volt Meter to the 50 VDC range. Touch the black (-) probe to the negative (-) contact of the vehicle D.C. receptacle and the red (+) probe to the positive (+) contact of the vehicle D.C. receptacle (FIG. 20, and FIG. 24)

A meter reading of 24 VDC \pm 5 VDC indicates that the batteries are satisfactory. A reading below 24 VDC \pm 5 V indicates that one or all batteries are defective or are in need of charging (see Batteries section for testing procedures). No reading indicates an 'open' condition and the following procedure should be followed.

Locate the black (-) probe on the negative (BL-) post of the battery. Locate the red (+) probe to the positive side of the solenoid. A meter reading of 24 VDC \pm 5 V indicates that the wire joining (BL+) to solenoid is satisfactory.

A reading of less than 24 VDC \pm 5 V indicates a broken wire, a poor connection, or corrosion at either the battery or motor termination.

Locate the black (-) probe on the negative (BL-) post of the battery. Locate the positive probe on the negative (-) side of the solenoid. A meter reading of 20 VDC \pm 4 V indicates that the resistor on the solenoid is satisfactory. A meter reading of approximately '0' VDC indicates that the resistor is 'closed' which requires inspection of the the sole-

ELECTRICAL - SOLID STATE SPEED CONTROL

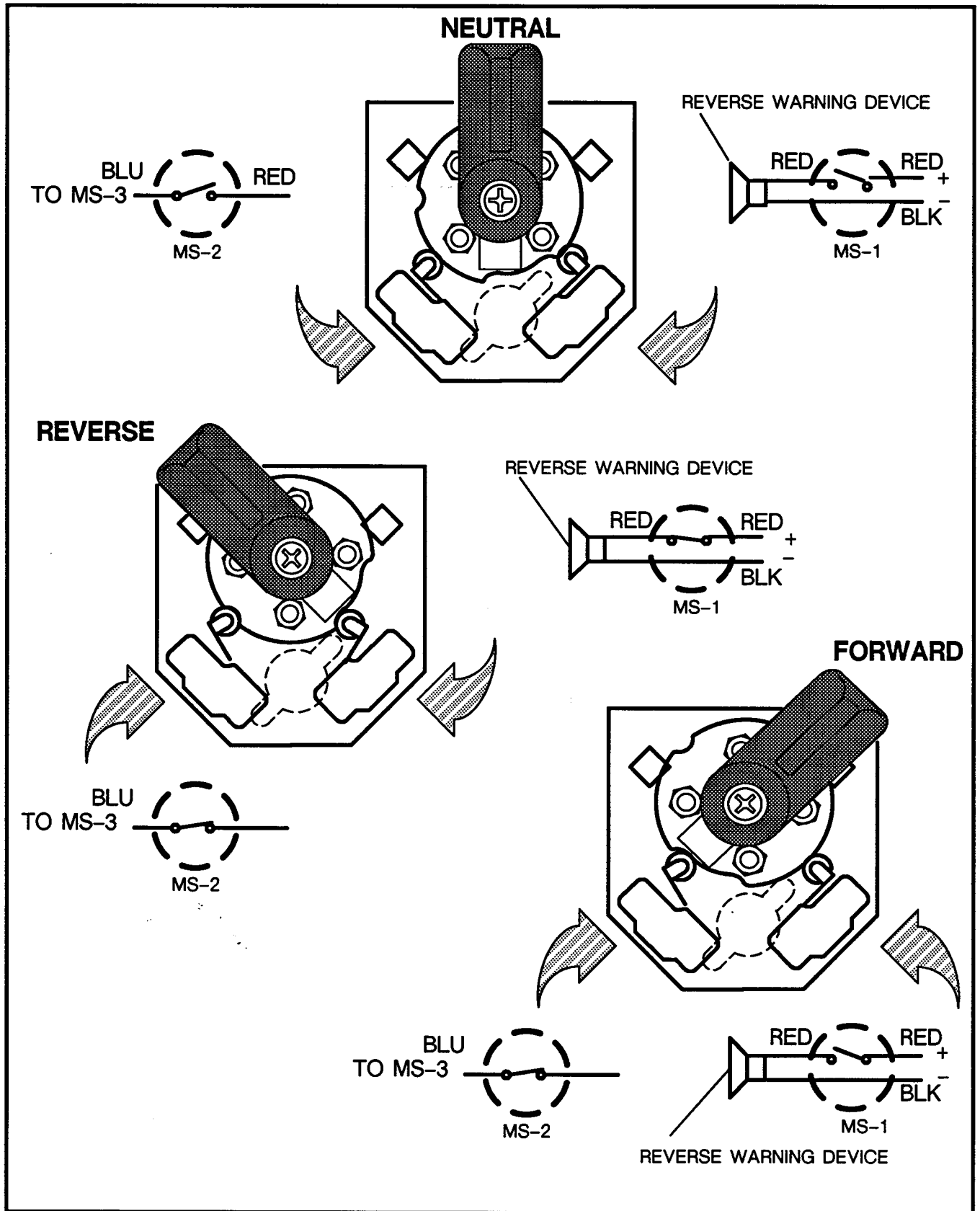

FIG. 22 F-N-R MICRO SWITCHES AND REVERSE WARNING DEVICE

ELECTRICAL - SOLID STATE SPEED CONTROL

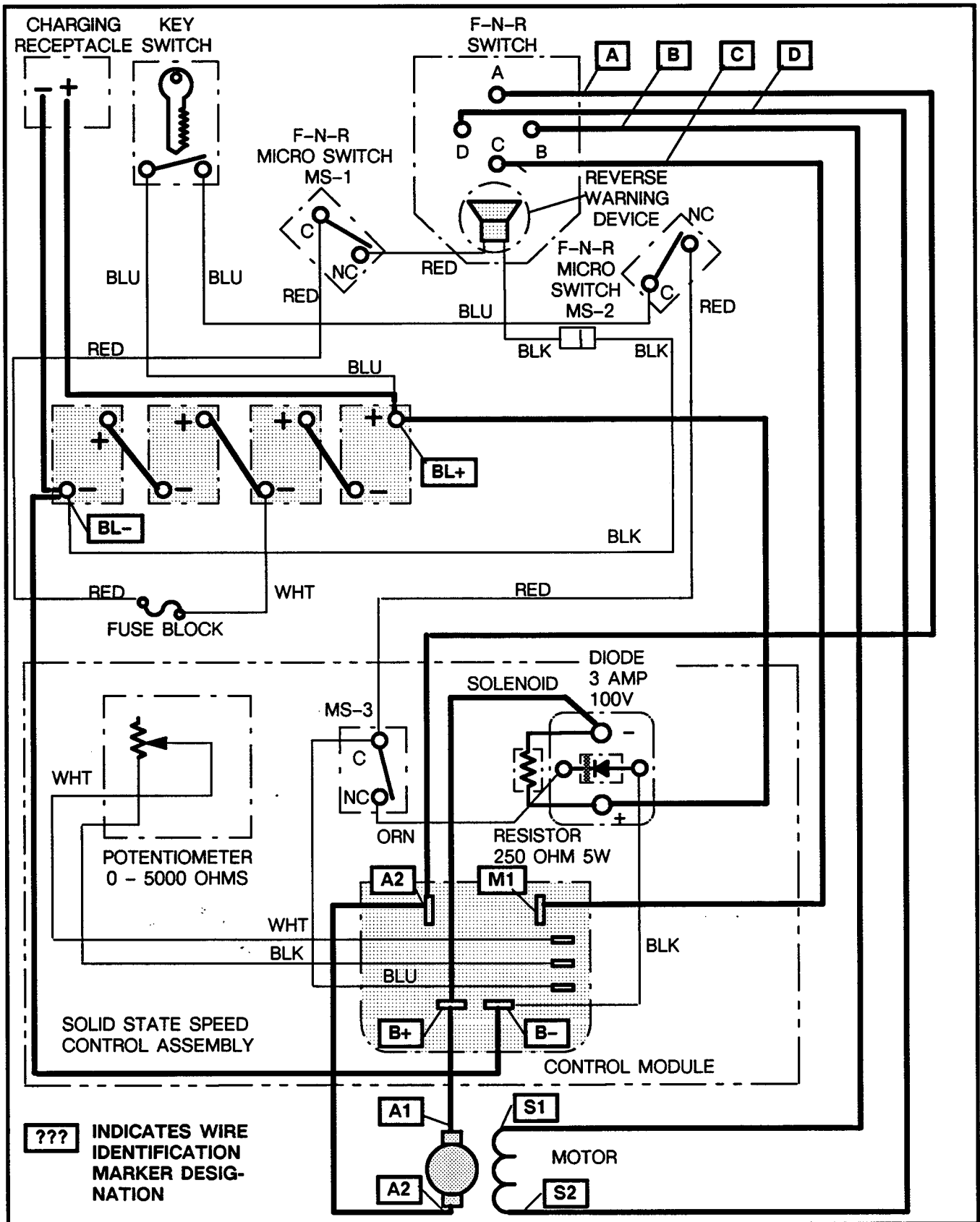

FIG. 23 POWER WIRING DIAGRAM

ELECTRICAL – SOLID STATE SPEED CONTROL

noid to determine if repair or replacement is needed.

NOTE

When testing for voltage from the negative side of the solenoid a meter reading of 20 VDC \pm 4 V indicates a satisfactory condition. Reduced voltage is observed due to the resistor located on the solenoid.

Locate the red (+) probe to the motor terminal A1. A meter reading of 20 VDC \pm 4 V indicates continuity between the solenoid and A1 on motor. A reading of '0' VDC indicates an 'open' circuit and should be repaired.

Locate the red (+) probe on (B+) terminal on the controller. A reading of 20 VDC \pm 4 V indicates that the solenoid wire to (B+) on controller is satisfactory. A reading of '0' VDC indicates an 'open' condition that should be repaired.

Locate the red (+) probe on motor terminal to A2. A reading of 20 VDC \pm 4 V indicates that the armature and the motor is satisfactory. A meter reading of '0' VDC requires repair or replacement of the motor.

Locate the red (+) probe on the A2 lead of the controller. A reading of 20 VDC \pm 4 V indicates that the wire between A2 on the motor and the controller is satisfactory. A reading of '0' VDC indicates an 'open' circuit and the wire should be repaired or replaced.

Locate the red (+) probe on A contact of the F-N-R switch. A reading of 20 VDC \pm 4 V indicates that the wire between A2 on the controller and A contact on the F-N-R switch is satisfactory. A reading of '0' VDC indicates an 'open' circuit and the wire should be repaired or replaced.

Locate the red (+) probe on B contact of the F-N-R switch. A reading of 20 VDC \pm 4 V indicates satisfactory connection between A and B terminals of the F-N-R switch. A reading of '0' VDC indicates an 'open' circuit and the F-N-R switch should be repaired or replaced.

Locate the red (+) probe to the S1 terminal on the motor. A meter reading of 20 VDC \pm 4 V indicates satisfactory connection between S1 on motor and B

on F-N-R. A reading of '0' VDC indicates an 'open' circuit and the wire between B on F-N-R and S1 on motor should be repaired or replaced.

Locate the red (+) probe on S2 terminal on the motor. A meter reading of 20 VDC \pm 4 V indicates that the field coil is satisfactory. A meter reading of '0' VDC indicates an 'open' circuit which would require the repair or replacement of the motor.

Locate the red (+) probe on the D contact of the F-N-R switch. A meter reading of 20 VDC \pm 4 V indicates that the wire between S2 on the motor and D on the F-N-R switch is satisfactory. A meter reading of '0' VDC indicates an 'open' circuit and the wire between S2 on motor and D on F-N-R should be repaired or replaced.

Locate the red (+) probe on C contact of the F-N-R switch. A meter reading of 20 VDC \pm 4 V indicates satisfactory connection between D and C terminals of the F-N-R switch. A meter reading of '0' VDC indicates an 'open' circuit and the F-N-R switch should be repaired or replaced.

Locate the red (+) probe on M1 of the controller. A meter reading of 20 VDC \pm 4 V indicates satisfactory connection between C terminal of F-N-R switch and M1 on controller. A reading of '0' VDC indicates an 'open' circuit and the wire between C terminal on F-N-R and M1 on controller should be repaired or replaced.

CAUTION

REMOVE BATTERY (-) CONNECTIONS BEFORE USING OHMMETER FOR THE FOLLOWING TEST.

Select the volt ohm meter to the ohms RX1 scale. Locate black (-) probe on (BL-) wire. Locate red (+) probe on (B-) contact of the controller. A meter reading of 3 ohms or less is satisfactory. A meter reading of more than 3 ohms indicates that wire (BL-) to B contact on the controller should be repaired or replaced. Replace the battery (BL-) connections.

IF THE VEHICLE RUNS BUT PERFORMS ERRATICALLY:

ELECTRICAL - SOLID STATE SPEED CONTROL

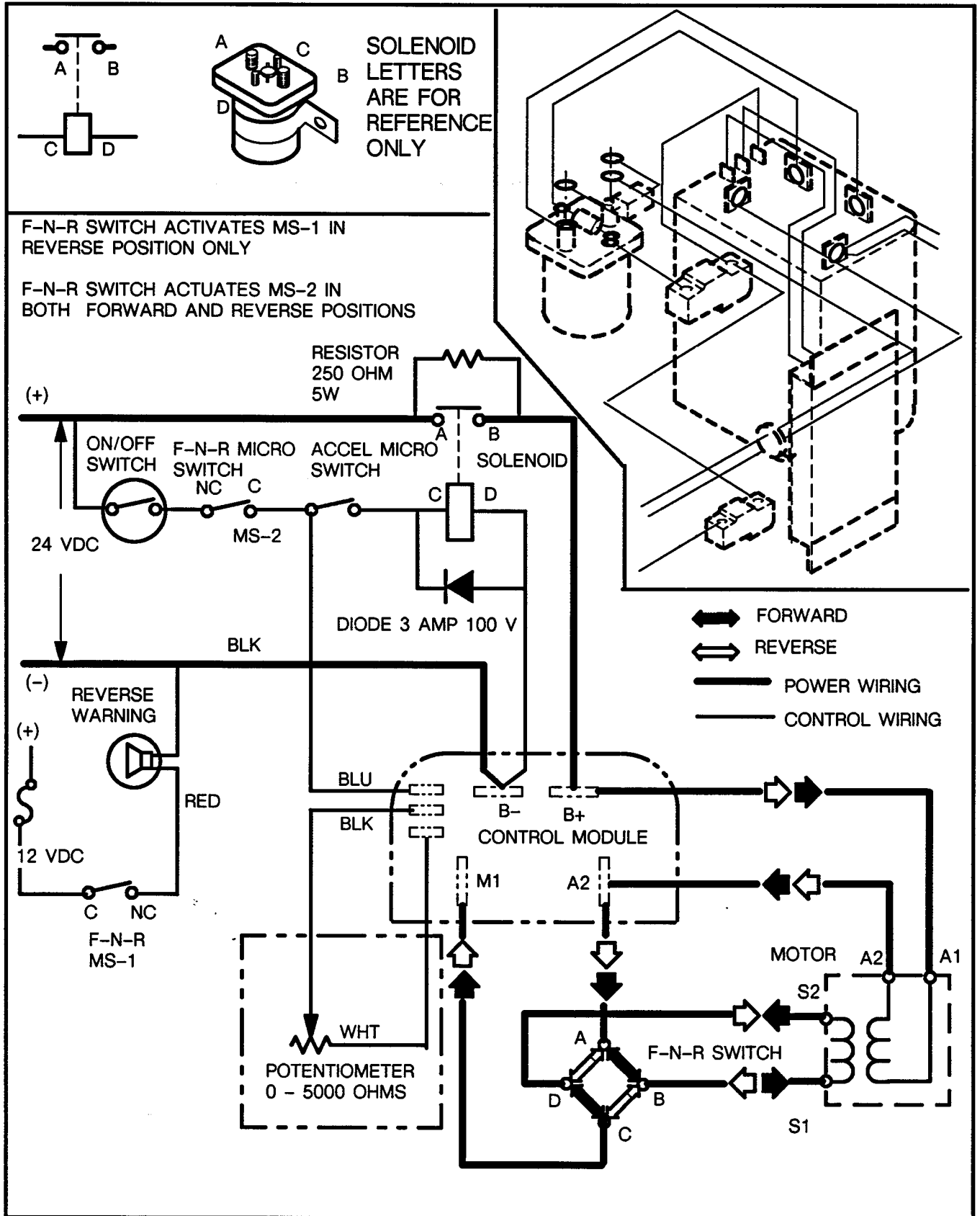

FIG. 24 WIRING DIAGRAM

ELECTRICAL – SOLID STATE SPEED CONTROL



WARNING

TO PREVENT THE VEHICLE FROM INADVERTENTLY ACCELERATING, WHICH COULD CAUSE BODILY INJURY, THE VEHICLE MUST BE LIFTED TO RAISE BOTH DRIVE WHEELS ABOVE THE GROUND.

Raise the vehicle before proceeding.

Place key switch in the 'ON' position and the F-N-R switch to the 'FORWARD' (F) position.

Visually inspect all components for burned or broken wires or loose connections. Inspect all terminals for corrosion and clean if required. If a visual inspection fails to yield the cause of the problem, an ohmmeter may be used to perform a 'continuity' test at each component.

CHECKING FOR CONTINUITY

The ohmmeter can be very useful in testing for continuity. A wire conductor that is continuous without a break has partially zero ohms of resistance. When testing for continuity, be sure that the ohmmeter is set to the lowest ohms range.

There are many applications. Because of the insulated cover, a wire conductor can have an internal break which is not visible, or the wire can have a bad connection at the terminal.

When testing for continuity, check for zero ohms between any two points along the conductor. A break in the conducting path is evident from a reading of infinite resistance (∞) showing an open circuit.



REMOVE BATTERY (+) CONNECTIONS BEFORE USING OHMMETER.



A test light may be substituted for an ohmmeter.

If the vehicle continues to run with the accelerator pedal in the released position, the accelerator linkage is out of adjustment (see Accelerator Adjustment).

TESTING THE MOTOR (FIG. 24)



This test is valid only after the control and power wiring has been inspected as detailed in the preceding procedures.

Tools Required:	Qty.
V.O.M.	1



WARNING

TO PREVENT THE VEHICLE FROM INADVERTENTLY ACCELERATING, WHICH COULD CAUSE BODILY INJURY, THE VEHICLE MUST BE LIFTED TO RAISE BOTH DRIVE WHEELS ABOVE THE GROUND.

Raise the vehicle before proceeding.

Place key switch in the 'ON' position and the F-N-R switch to the 'FORWARD' (F) position.



Use the following test *ONLY IF THE MOTOR WILL NOT RUN.*

This check is for open circuits in field coils, brushes, or brush rigging. To check for a short circuit, refer to the Motor Section.

Set the volt meter to the 50 VDC range.

Locate the black (-) probe to the negative (-) contact of the vehicle D.C. receptacle and the red (+) probe to the motor terminal S2. A meter reading of 20 VDC \pm 4 V indicates a good condition. Locate the red (+) probe on the motor terminal S1. A meter reading of 20 VDC \pm 4 V indicates that the field coils are satisfactory. A meter reading of '0' indicates that the field coils are open and the motor must be repaired or replaced.

Locate the red (+) probe on the motor terminal A2. A reading other than '0' VDC indicates that the power wiring should be rechecked. Locate the red (+) probe to the motor terminal A1. A meter reading of 20 VDC \pm 4 VDC indicates that the brushes, brush holder, and all connections are satisfactory. A meter reading of '0' indicates a problem with the brushes, brush holder, or connections.

ELECTRICAL – SOLID STATE SPEED CONTROL

The following tests may be performed with an ohmmeter or test light.



WARNING

REMOVE BATTERY (+) CONNECTIONS BEFORE CONTINUING WITH THIS TEST. SHORTING OF MOTOR WIRES COULD RESULT IN AN EXPLOSION.

Remove wires from motor terminals A1 and S2. Set the ohmmeter to the RX1 scale. Using the ohmmeter, place probes on motor terminals S1 and S2. A meter reading of '0' indicates a satisfactory condition at the field coils. No needle deflection indicates an 'open' condition that will require the motor to be repaired or replaced.

Place the probes on motor terminals A1 and A2. A meter reading of '0' indicates a satisfactory condition at the brushes and rigging. No needle deflection indicates a condition that will require the motor to be repaired or replaced.

Check for continuity between each of the motor terminals and the motor shell. Continuity between terminals S1 and S2 to the motor shell indicates a short circuit between the field coils and the case. Continuity between terminals A1 or A2 to the motor shell indicates a short circuit in the armature. Both of the preceding conditions will require the motor to be repaired or replaced.

Tighten all motor terminal connections to 35–40 in. lbs. torque.

FORWARD–NEUTRAL–REVERSE SWITCH (FIG. 25)

The forward–neutral–reverse switch operation is described in Power Circuit at the beginning of this section.

SWITCH LUBRICATION

During the servicing of the vehicle, the F–N–R switch shaft should be removed, cleaned, and lubricated with bearing grease. The contact surfaces may also be lubricated with a thin coat of petroleum jelly to permit smooth operation of the switch.

FORWARD–NEUTRAL–REVERSE SWITCH INSPECTION AND REPAIR:



WARNING

DISCONNECT THE BATTERY LEAD (BL+) FROM THE BATTERY BEFORE ATTEMPTING SERVICE OF THE FORWARD–NEUTRAL–REVERSE SWITCH.

Periodic inspection of the switch should include the following:

1. Check that all wire connections are tight and free of corrosion.
2. Check the contacts for abnormal wear. The contacts in the movable cam portion of the switch are spring loaded and the cam assembly must be replaced when worn sufficiently to cause a loss of spring pressure.
3. Rotate the switch lever from 'stop to stop' to check for smooth operation. If the switch is excessively hard to operate, inspect for rough contact surfaces and replace if required. If the contact surfaces are good, the stationary contact surfaces may be lubricated, if required, with a very thin coat of petroleum jelly.

If the switch is abnormally loose, check the shaft nut and tighten if required. Inspect for abnormally worn spring loaded contacts.

Inspect the micro switches for operation and dirt that might inhibit their operation.

Reassemble in the reverse order of disassembly.

FORWARD–NEUTRAL–REVERSE SWITCH REMOVAL AND DISASSEMBLY (FIG. 25)

Tools Required: Qty.

- | | |
|---|---|
| Wrench, box end combination, 7/16"–1/2" | 1 |
| Wrench, box end, 9/16" | 1 |
| Screwdriver, Phillips | 1 |

Remove lever (1) from shaft (2).

Disconnect all of the wiring connections from the rear of the switch, disconnect push–on connections and any other connections securing the switch to the vehicle electrical system. Disconnect the wire from

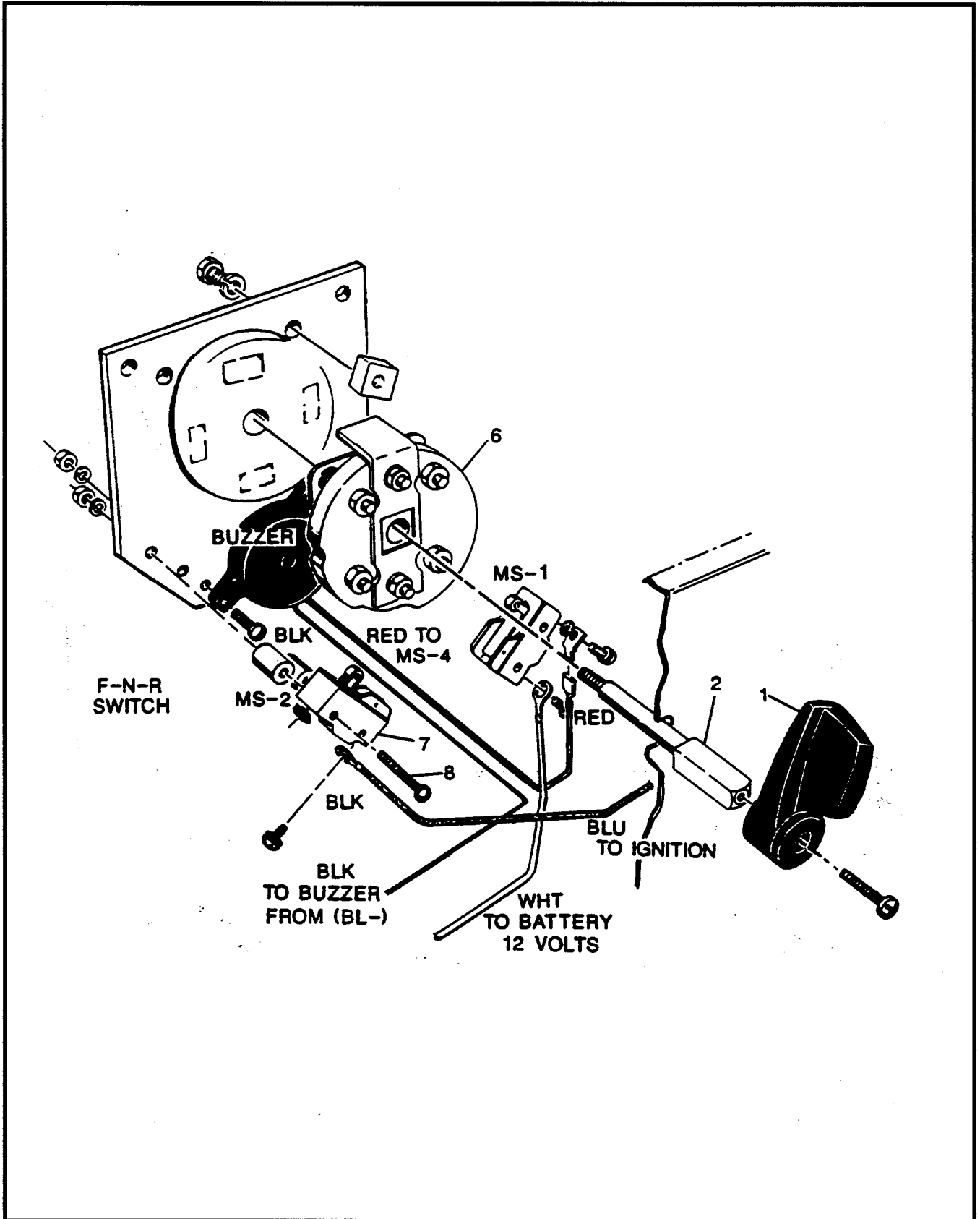

FIG. 25 FORWARD-NEUTRAL-REVERSE SWITCH ASSEMBLY

ELECTRICAL – SOLID STATE SPEED CONTROL

the micro switch to the key switch at micro switch 2 (MS-2).

Remove the hardware (3) which secures the switch to the seat wrap (4) and remove the switch assembly.

Remove the nut (5) from the switch shaft (2), remove the cam (6) complete with the shaft (2) from

the bushing and remove the shaft (2) from the cam assembly (6).

Reassemble the switch in the reverse order of disassembly. Rotate the cam from stop to stop and check the operation of the micro switch (7) rollers.

Reinstall the F-N-R switch in the vehicle and adjust the switch to align with the hole in the seat wrap.

Tighten the hardware that secures the F-N-R switch to the vehicle to 10-12 ft. lbs. torque.

OPERATION AND MAINTENANCE

SECTION: GENERAL SPECIFICATIONS

PERSONNEL CARRIER - (835)

WEIGHT (WITHOUT BATTERIES)	520 POUNDS
LENGTH	82.25 INCHES
WIDTH	29.5 INCHES (WITHOUT SPACER, WITH 4.80 TIRES) 31.3 INCHES (WITH SPACER, WITH 5.70 TIRES)
HEIGHT (AT STEERING WHEEL)	45.2 INCHES
FLOOR HEIGHT	7.6 INCHES
CARGO DECK HEIGHT	20.0 INCHES (22.6 INCHES TO TOP OF FRAME)
CARGO DECK SIZE	27 INCHES WIDE 20 INCHES LONG
CARGO DECK	REMOVABLE FOR ACCESS TO DRIVE PACKAGE
LOAD CAPACITY	550 POUNDS (INCLUDING OPERATOR, PASSENGER AND ACCESSORIES)
GROUND CLEARANCE (AT DIFFERENTIAL)	4.0 INCHES
SEAT HEIGHT	26 INCHES
SEATING	FABRIC BACKED, CUSHION FOAM BENCH SEAT AND SEAT BACK WITH FOLD DOWN REAR SEAT FOR ONE OR TWO OCCUPANTS
WHEEL BASE	52.0 INCHES
TURNING CLEARANCE DIAMETER	144.5 INCHES
INTERSECTING AISLE CLEARANCE	51.0 INCHES
TIRES	4.80 X 8, 6 PLY RATED INDUSTRIAL TIRES, FRONT AND REAR
ELECTRICAL SYSTEM	24 VOLT D.C., 6 VOLT, (4) DEEP CYCLE LEAD ACID BATTERIES (105 MINUTES, 220 AMP- HOUR)
BRAKES	AUTO-ADJUSTING, DUAL REAR WHEEL DRUMS
ACCELERATOR SWITCH	SOLID STATE CONTINUOUSLY VARIABLE SPEED CONTROLLER
DRIVE TRAIN	DIRECT, MOTOR SHAFT CONNECTED TO TRANSAXLE PINION SHAFT

GENERAL SPECIFICATIONS

TRANSAXLE	HIGH EFFICIENCY, DOUBLE REDUCTION HELICAL TYPE, 14.78 TO 1 RATIO
SPEED (MAXIMUM)	9 M.P.H.
SUSPENSION	REAR: HEAVY DUTY COIL SPRINGS WITH HYDRAULIC SHOCK ABSORBERS FRONT: .75 INCH DIAMETER SOLID AXLE
STEERING	DOUBLE REDUCTION RACK AND PINION
BODY	HEAVY DUTY TREADPLATE
CHASSIS	WELDED HIGH YIELD STRENGTH TUBULAR STEEL
CHARGER	TOTAL CHARGE [®] ₁ 24 VOLTS D.C. (ON BOARD) U.L. LISTED
LIGHTING	HALOGEN HEADLIGHTS, DUAL TAILLIGHTS AND BRAKE LIGHTS
SAFETY	HORN, FORWARD - NEUTRAL - REVERSE SWITCH, REVERSE WARNING DEVICE, HANDGRIP AND HIP RESTRAINT, REMOVABLE KEY SWITCH, "DEADMAN" ACCELERATOR CONTROL AND REVERSE WARNING IN- DICATOR
MOTOR	24 VOLT D.C. SERIES WOUND, SOLID COPPER WINDINGS, 2 H.P. AT 2800 R.P.M. AND 4.3 H.P. AT 1200 R.P.M.

SPECIFICATIONS ARE SUBJECT TO CHANGE WITHOUT NOTICE.

ILLUSTRATED PARTS BREAKDOWN
ELECTRIC POWERED PERSONNEL CARRIER

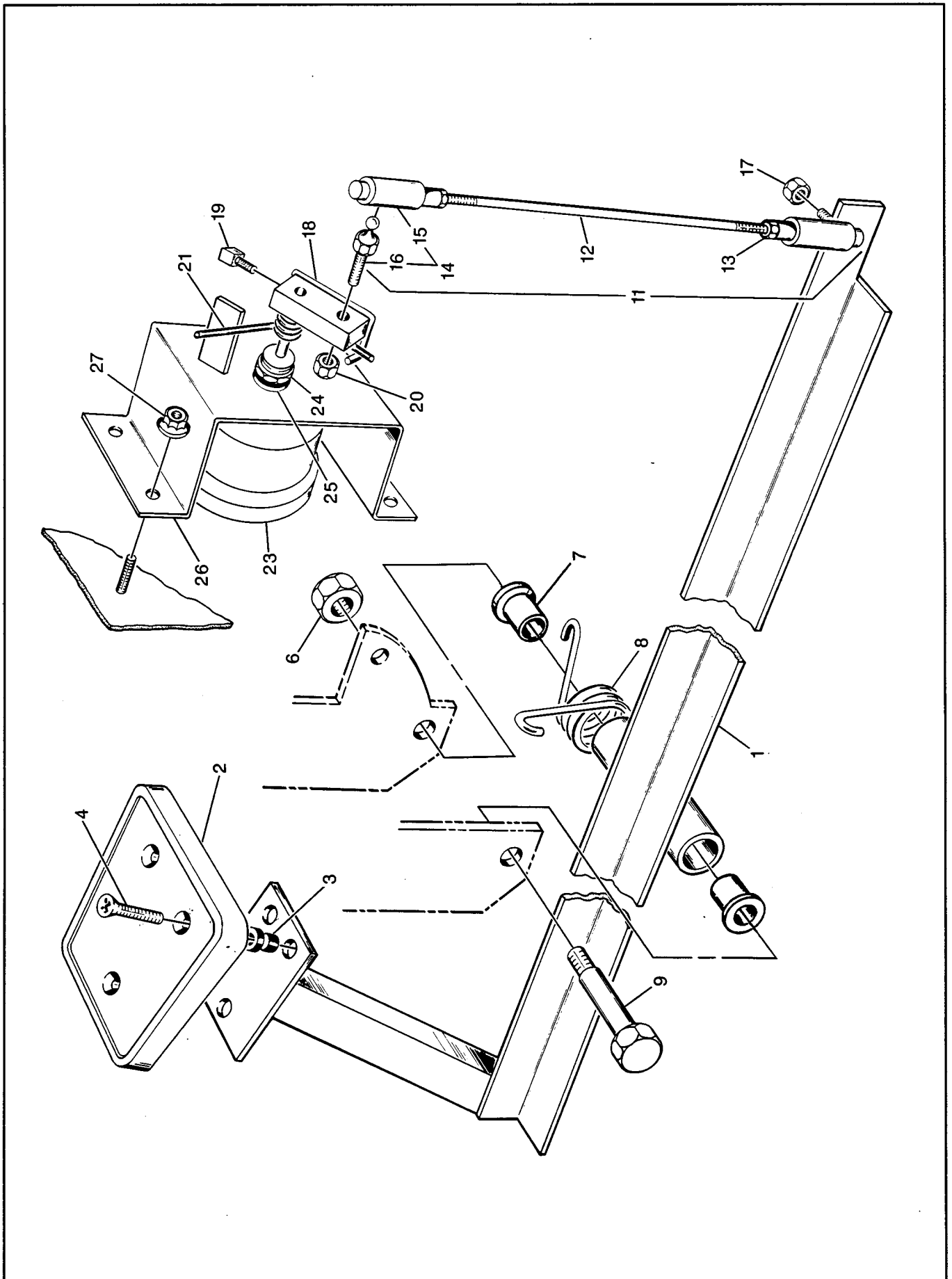

ACCELERATOR PEDAL (SOLID STATE SPEED CONTROL)

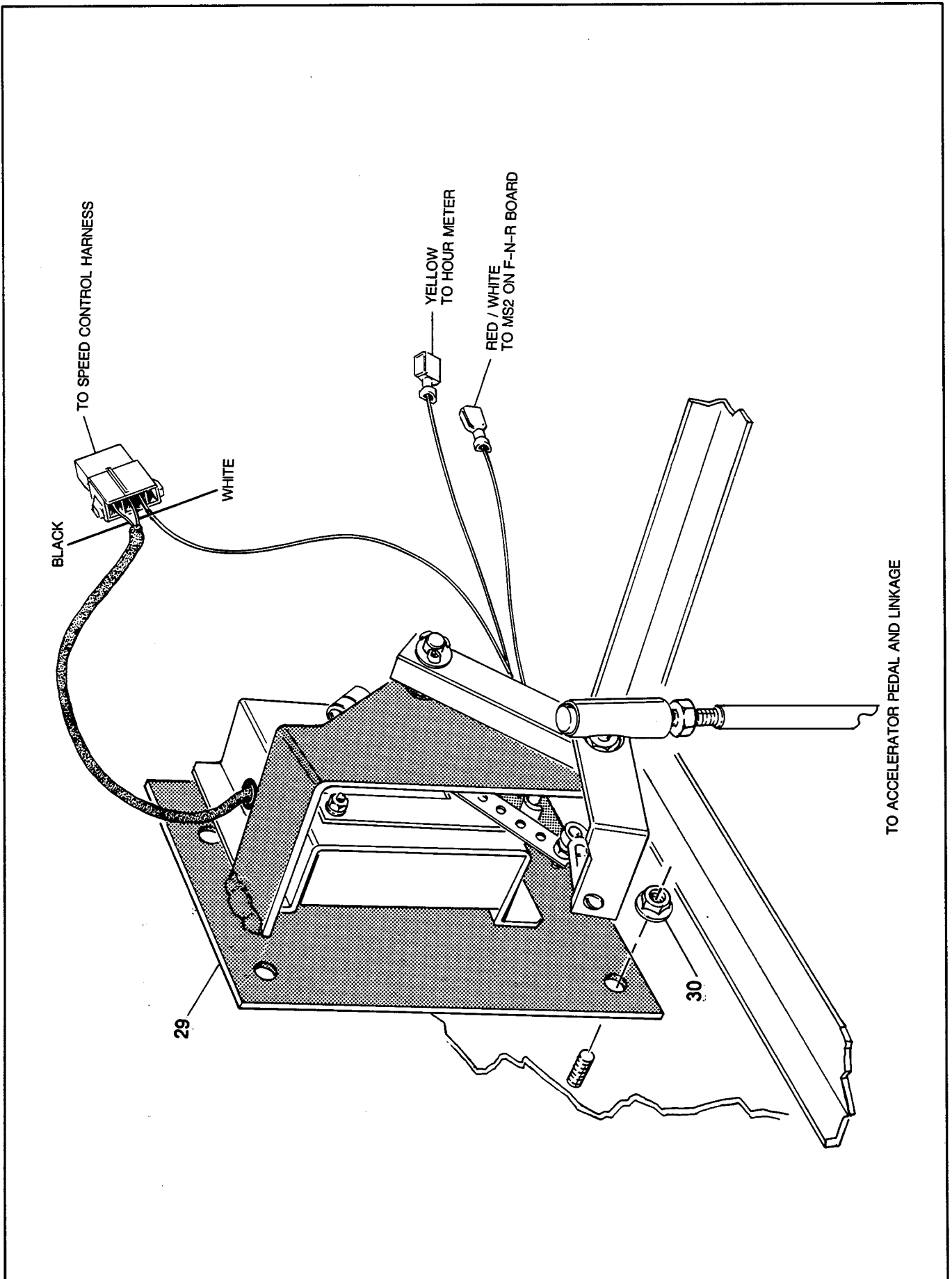

ACCELERATOR PEDAL (RESISTOR COIL AND SOLID STATE SPEED CONTROL)

THE USE OF NON U.L. PARTS WILL VOID ANY U.L. LISTING.

When ordering parts, please specify the model and serial number of the product.

* Indicates a component that is not available as an individual part.

MODEL		
ESC	RCV	

ITEM	PART NO.	1	2	3	4	5	DESCRIPTION	QTY		
								ESC	RCV	
1	32854-G1						ACCELERATOR PEDAL	1	1	
2	30330-G1						BRAKE PEDAL PAD	1	1	
3	00739-G1						NUT, #10 - 24	3	3	
4	00741-G7						SCREW, #10 - 24 X 7/8 LG.	3	3	
5										
6	13521-G4						NUT, LOCK, 3/8 - 16	1	1	
7	10097-G7						BUSHING, FLANGED	2	2	
8	13197-G1						SPRING, TORSION	1	1	
9	14158-G1						BOLT, SHOULDER, 3/8 - 16	1	1	
10										
11	32364-G1						ACCELERATOR ROD ASSEMBLY (INCLUDES ITEMS 12 - 16)	1	1	
12	18038-G2						THREADED ROD	1	1	
13	00544-G4						NUT, 5/16 - 24	2	2	
14	10089-G3						BALL JOINT (INCLUDES ITEMS 15,16)	2	2	
15	14444-G3						BALL JOINT, SOCKET	1	1	
16	15944-G3						BALL JOINT, BALL	1	1	
17	11098-G9						NUT, LOCK, 5/16 - 24	1	1	
18	32361-G1						LINK	-	1	
19	00491-G4						SCREW, SQUARE, 1/4 - 20 X 1/2 LG.	-	1	
20	00544-G4						NUT, 5/16 - 24	-	1	
21	31479-G1						SPRING, TORSION	-	1	
22										
23	30210-G1						SWITCH, ACCELERATOR (INCLUDES ITEMS 24, 25)	-	1	
24	*						NUT	-	1	
25	*						WASHER, LOCK	-	1	
26	32199-G1						BRACKET, ACCELERATOR SWITCH	-	1	
27	11027-G2						NUT, LOCK, 1/4 - 20	-	4	
28										
29	32551-G1						POTENTIOMETER SUPPORT ASSEMBLY	1	-	
30	11027-G2						NUT, LOCK, 1/4 - 20	4	-	

ACCELERATOR PEDAL (RESISTOR COIL AND SOLID STATE SPEED CONTROL)

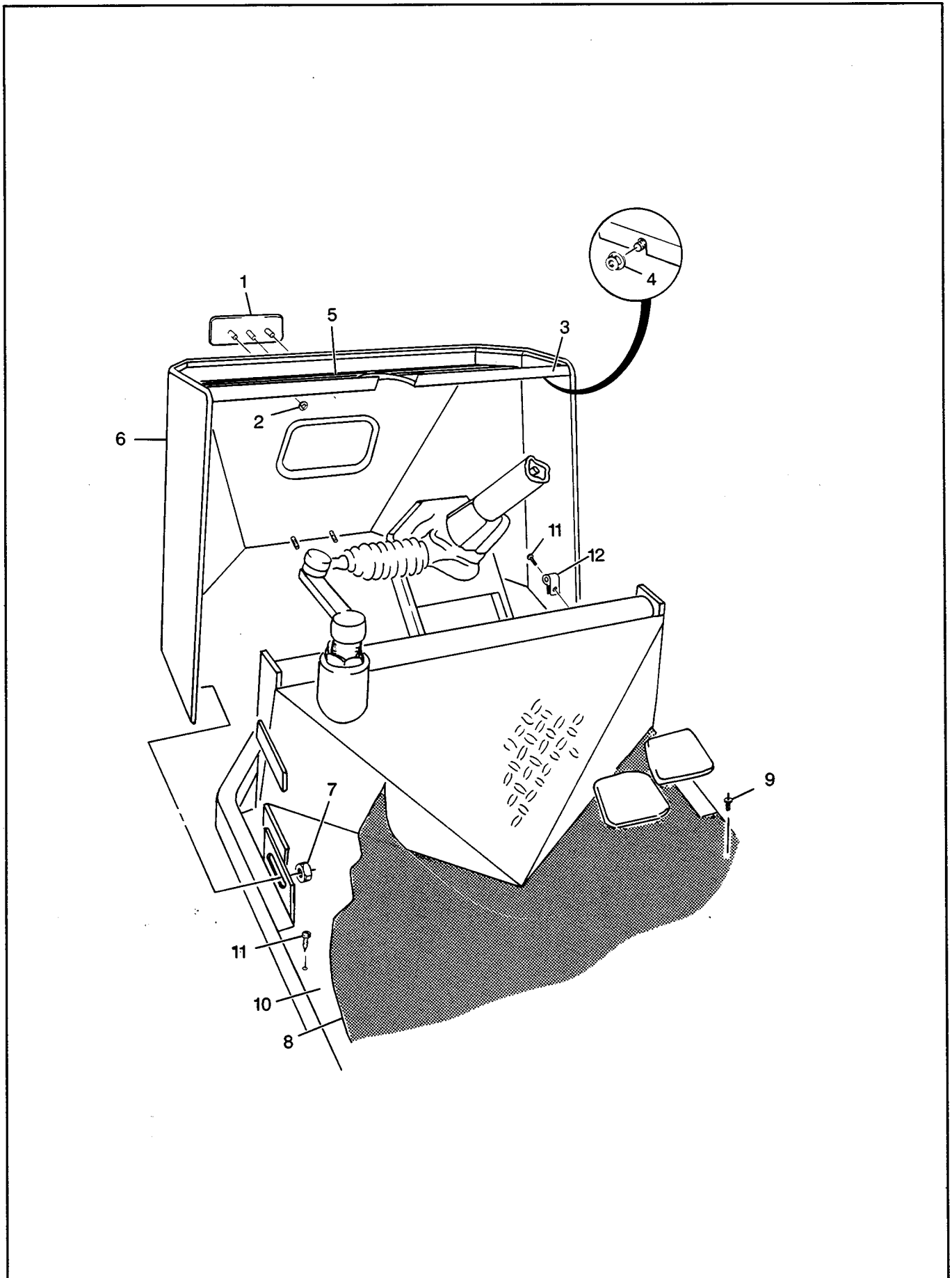

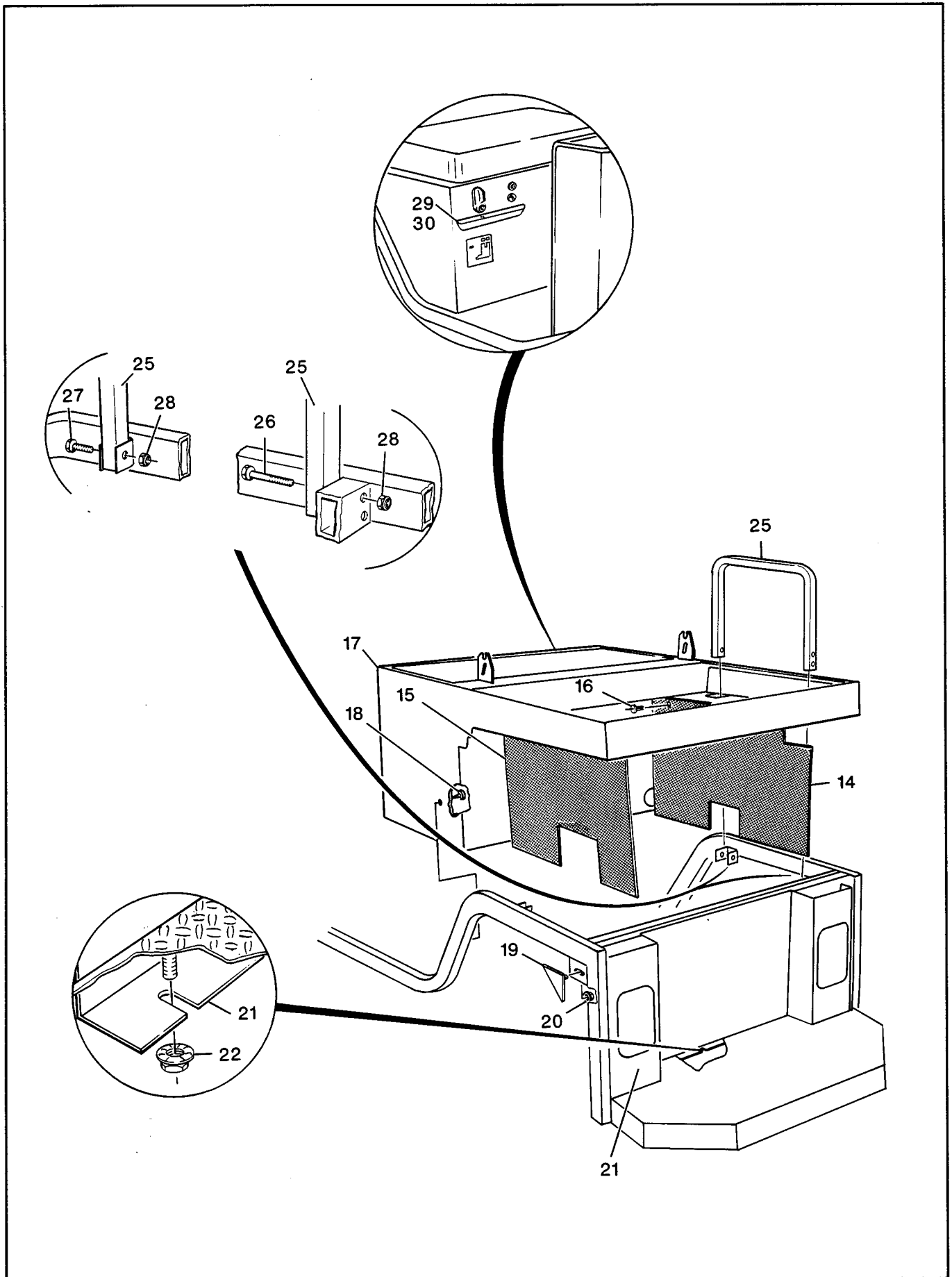

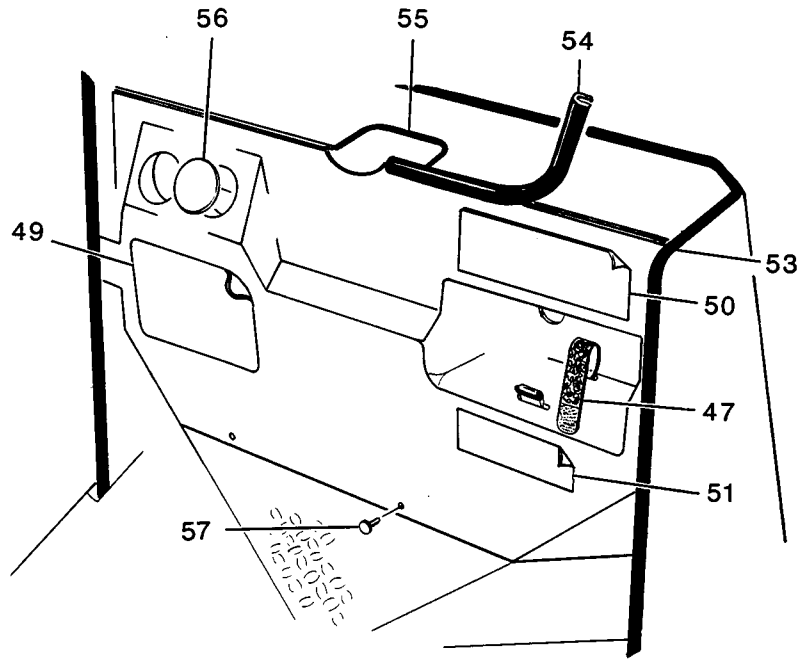

SEE BATTERY CHARGER ILLUSTRATION

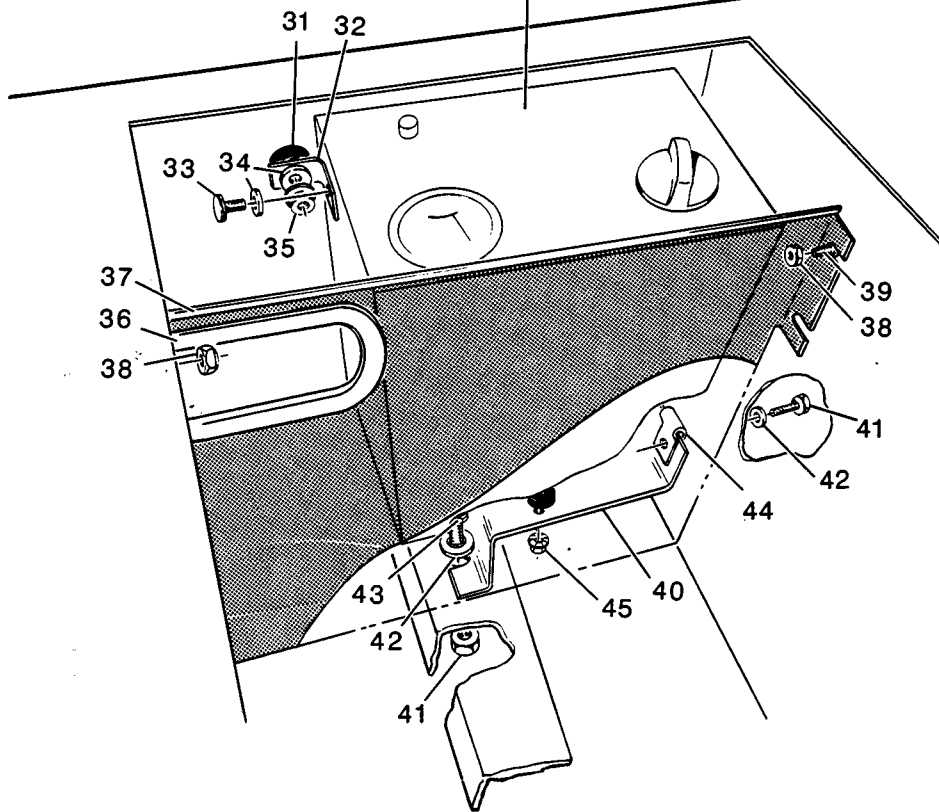

BODY AND ASSOCIATED PARTS

THE USE OF NON U.L. PARTS WILL VOID ANY U.L. LISTING.

When ordering parts, please specify the model and serial number of the product.

* Indicates a component that is not available as an individual part.

MODEL		
	835	

ITEM	PART NO.	1 2 3 4 5	DESCRIPTION	QTY		
1	19817-G1		NAMEPLATE, E-Z-GO		1	
2	12064-G3		NUT, PUSH-ON		3	
3	32130-G1		TRAY, DASH		1	
4	11027-G2		NUT, LOCK, 1/4 - 20		4	
5	32370-G1		MAT, DASH TRAY		1	
6	32254-G2		COWL		1	
7	11027-G2		NUT, LOCK, 1/4 - 20		4	
8	32292-G1		FLOORMAT		1	
9	19436-G1		RIVET, PLASTIC DRIVE		4	
10	32004-G2		FLOORBOARD		1	
11	00106-G6		SCREW, SELF DRILL AND TAP, #12 - 24 X 3/4 LG.		13	
12	30388-G1		CLAMP		1	
13						
14	32367-G1		SKIRT, FENDER, R.H.		1	
15	32367-G2		SKIRT, FENDER, L.H.		1	
16	18436-G1		RIVET, DRIVE		6	
17	32248-G3		BODY		1	
18	00106-G6		SCREW, SELF DRILL AND TAP, #12 - 24 X 3/4 LG.		2	
19	32151-G1		TRIM, CORNER		2	
20	11027-G2		NUT, LOCK, 1/4 - 20		2	
21	32106-G2		PANEL, REAR		1	
22	11027-G2		NUT, LOCK, 1/4 - 20		4	
23						
24						
25	32462-G1		RAIL, HAND		2	
26	00685-G8		SCREW, STAINLESS STEEL, 5/16 - 18 X 2 LG.		4	
27	00685-G1		SCREW, STAINLESS STEEL, 5/16 - 18 X 1 1/2 LG.		2	
28	00891-G3		NUT, LOCK, 5/16 - 18		6	
29	19882-G1		INDICATOR, F - N - R		1	
30	12064-G3		NUT, PUSH ON		3	
31	32478-G1		MOUNT, ISOLATION		1	
32	32468-G1		BRACKET, CHARGER MOUNTING		1	
33	00661-G6		SCREW, STAINLESS STEEL, 1/4 - 20 X 3/4 LG.		1	
34	00660-G7		WASHER, NARROW, STAINLESS STEEL, 1/4		2	

BODY AND ASSOCIATED PARTS

THE USE OF NON U.L. PARTS WILL VOID ANY U.L. LISTING.

When ordering parts, please specify the model and serial number of the product.

* Indicates a component that is not available as an individual part.

							MODEL	
							835	
ITEM	PART NO.	1	2	3	4	5	DESCRIPTION	QTY
35	11027-G2						NUT, LOCK, 1/4 - 20	1
36	32349-G1						PANEL, SPLASH	1
37	32372-G1						TRIM, SPLASH PANEL	1
38	11027-G2						NUT, LOCK, 1/4 - 20	4
39	16705-G2						SCREW, STAINLESS STEEL, 1/4 - 20 X 5/8 LG.	2
40	32362-G1						BRACKET, CHARGER	1
41	00891-G2						NUT, LOCK, 1/4 - 20	2
42	00660-G7						WASHER, STAINLESS STEEL, 1/4	4
43	00661-G6						SCREW, STAINLESS STEEL, 1/4 - 20 X 3/4 LG.	4
44	14776-G1						NUT, 1/4 - 20	2
45	11027-G2						NUT, LOCK, 1/4 -20	4
46	32382-G1						DASH PANEL	1
47	32384-G1						STRAP, VELCRO	1
48								
49	23446-G1						DECAL, SAFETY AND OPERATION INSTRUCTIONS	1
50	23615-G1						DECAL, ONBOARD CHARGER	1
51	23617-G1						LABEL, CAUTION	1
52								
53	22280-G1						TRIM, COWL (ORDER BY THE FOOT)	1
54	32805-G1						TRIM, DASH PANEL (ORDER BY THE FOOT)	2
55	22280-G1						TRIM, DASH TRAY (ORDER BY THE FOOT)	1
56	20271-G3						PLUG, HOLE	2
57	18436-G1						RIVET, DRIVE	2

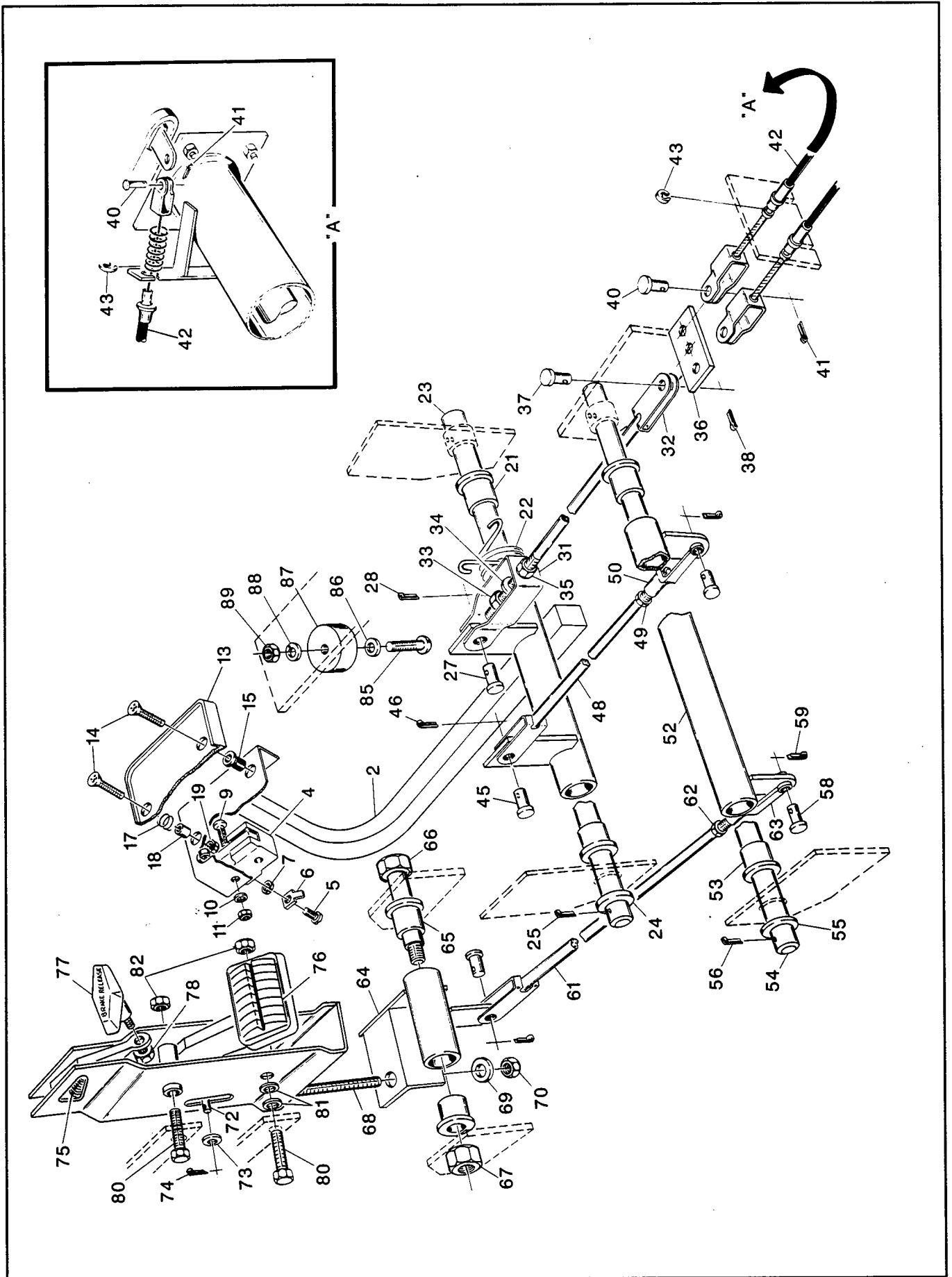

BRAKE LINKAGE

THE USE OF NON U.L. PARTS WILL VOID ANY U.L. LISTING.

When ordering parts, please specify the model and serial number of the product.

* Indicates a component that is not available as an individual part.

MODEL		
	835	

ITEM	PART NO.	1	2	3	4	5	DESCRIPTION	QTY		
1	32377-G1						BRAKE PEDAL ASSEMBLY (INCLUDES ITEMS 2 - 19)		1	
2	32273-G1						BRAKE PEDAL		1	
3										
4	10606-G1						SWITCH, MICRO		1	
5	*						SCREW		2	
6	14628-G1						TAB, FASTON		2	
7	00567-G3						WASHER, LOCK, #6		2	
8										
9	00366-G8						SCREW, #6 - 32 X 1 LG.		2	
10	00565-G4						WASHER, LOCK, #6		2	
11	00525-G5						NUT, #6 - 32		2	
12										
13	30330-G1						PAD, BRAKE PEDAL		1	
14	00741-G7						SCREW, #10 - 24 X 1 LG.		3	
15	00739-G1						NUT, #10 - 24		2	
16										
17	24938-G1						SPRING, CONICAL		1	
18	22362-G1						STANDOFF		1	
19	11098-G7						NUT, LOCK,#10 - 24		1	
20										
21	11079-G1						BUSHING		2	
22	25292-G1						SPRING, TORSION		1	
23	32398-G1						SHAFT, PIVOT		1	
24	00560-G3						WASHER, 1/2		1	
25	10387-G1						PIN, COTTER, 1/8 X 1 1/2 LG.		2	
26										
27	10386-G3						PIN, CLEVIS		1	
28	10387-G3						PIN, COTTER, 3/32 X 3/4 LG.		1	
29										
30	19960-G1						BRAKE YOKE ASSEMBLY		1	
31	19852-G1						YOKE, BRAKE		1	
32	19957-G1						JAW, TURNBUCKLE		1	
33	11098-G6						NUT, LOCK, 5/16 - 18		1	
34	00559-G8						WASHER, 5/16		1	

BRAKE LINKAGE

THE USE OF NON U.L. PARTS WILL VOID ANY U.L. LISTING.

When ordering parts, please specify the model and serial number of the product.

* Indicates a component that is not available as an individual part.

MODEL	
	835

ITEM	PART NO.	1	2	3	4	5	DESCRIPTION	QTY	
35	00532-G3						NUT, 5/16 - 18		1
36	13659-G1						BAR, EQUALIZER		1
37	10386-G3						PIN, CLEVIS		1
38	10387-G3						PIN, COTTER, 3/32 X 3/4 LG.		1
39									
40	10386-G3						PIN, CLEVIS		4
41	10387-G3						PIN, COTTER, 3/32 3/4 LG.		4
42	25124-G3						CABLE, BRAKE (SPRING LOADED)		2
43	12305-G1						RING, RETAINING		4
44									
45	10386-G3						PIN, CLEVIS		2
46	10387-G3						PIN, COTTER, 3/32 X 3/4 LG.		2
47									
48	30297-G5						ROD, LINKAGE, 9" THREADED		1
49	00544-G4						NUT, 5/16 - 24		1
50	10385-G4						YOKE, CLEVIS		1
51									
52	32275-G1						PIVOT		1
53	11079-G1						BUSHING		2
54	32398-G2						SHAFT, PIVOT		1
55	00560-G3						WASHER, 1/2		1
56	10387-G1						PIN, COTTER, 1/8 X 1 1/2 LG.		2
57									
58	10386-G3						PIN, CLEVIS		2
59	10387-G3						PIN, COTTER, 3/32 X 3/4 LG.		2
60									
61	30296-G6						ROD, LINKAGE, 20 3/4 THREADED		1
62	00544-G4						NUT, 5/16 - 24		1
63	10385-G4						YOKE, CLEVIS		1
64	32276-G1						PIVOT, BRAKE		1
65	11079-G1						BUSHING		2
66	14158-G1						BOLT, SHOULDER		1
67	13521-G4						NUT, LOCK, 3/8 - 16		1
68	30798-G2						LINK		1

BRAKE LINKAGE

THE USE OF NON U.L. PARTS WILL VOID ANY U.L. LISTING.

When ordering parts, please specify the model and serial number of the product.

* Indicates a component that is not available as an individual part.

						MODEL		
						835		
ITEM	PART NO.	1	2	3	4	5	DESCRIPTION	QTY
69	00559-G8						WASHER, 5/16	1
70	11098-G9						NUT, LOCK, 5/16 - 24	1
71	32272-G1						PEDAL ASSEMBLY (INCLUDES ITEMS 72 - 76)	1
72	*						PIN, CLEVIS	1
73	00559-G8						WASHER, 5/16	1
74	10387-G3						PIN, COTTER, 3/32 X 3/4 LG.	1
75	32535-G1						SPRING	1
76	32271-G1						PAD, FOOT LEVER	1
77	32340-G1						KNOB, BRAKE RELEASE	1
78	14390-G4						NUT, LOCK, 1/4 - 20	1
79								
80	00439-G8						SCREW, 5/16 - 18 X 2 LG.	2
81	00559-G8						WASHER, 5/16	2
82	11098-G6						NUT, LOCK, 5/16 - 18	2
83								
84	14061-G1						PEDAL BUMPER SERVICE KIT (INCLUDES ITEMS 85 - 89)	1
85	00150-G6						SCREW, #10 - 24 X 3/4 LG.	1
86	00559-G5						WASHER, #10	1
87	13728-G1						BUMPER, RUBBER	1
88	00559-G5						WASHER, #10	1
89	00526-G3						NUT, #10 - 24	1

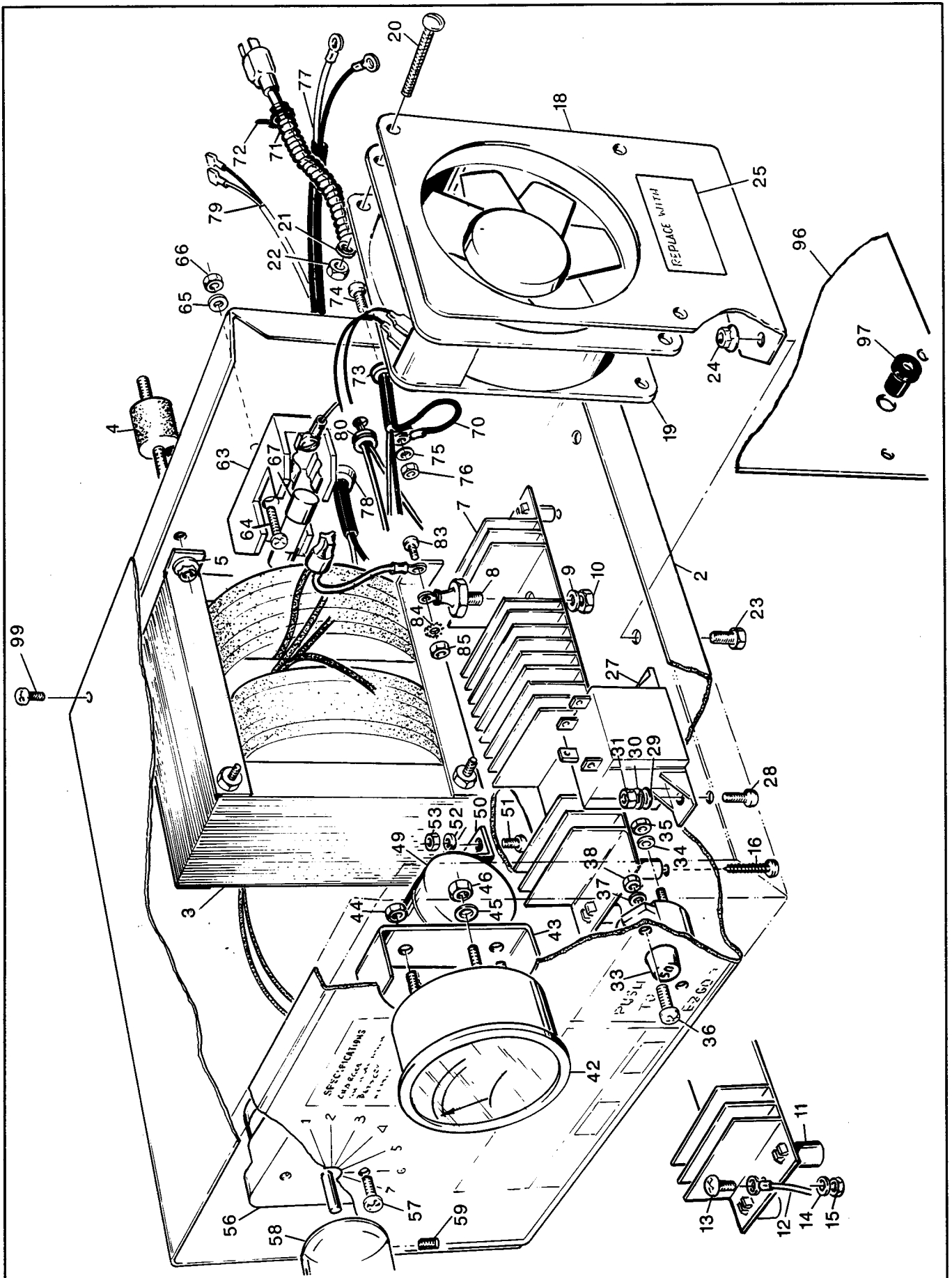

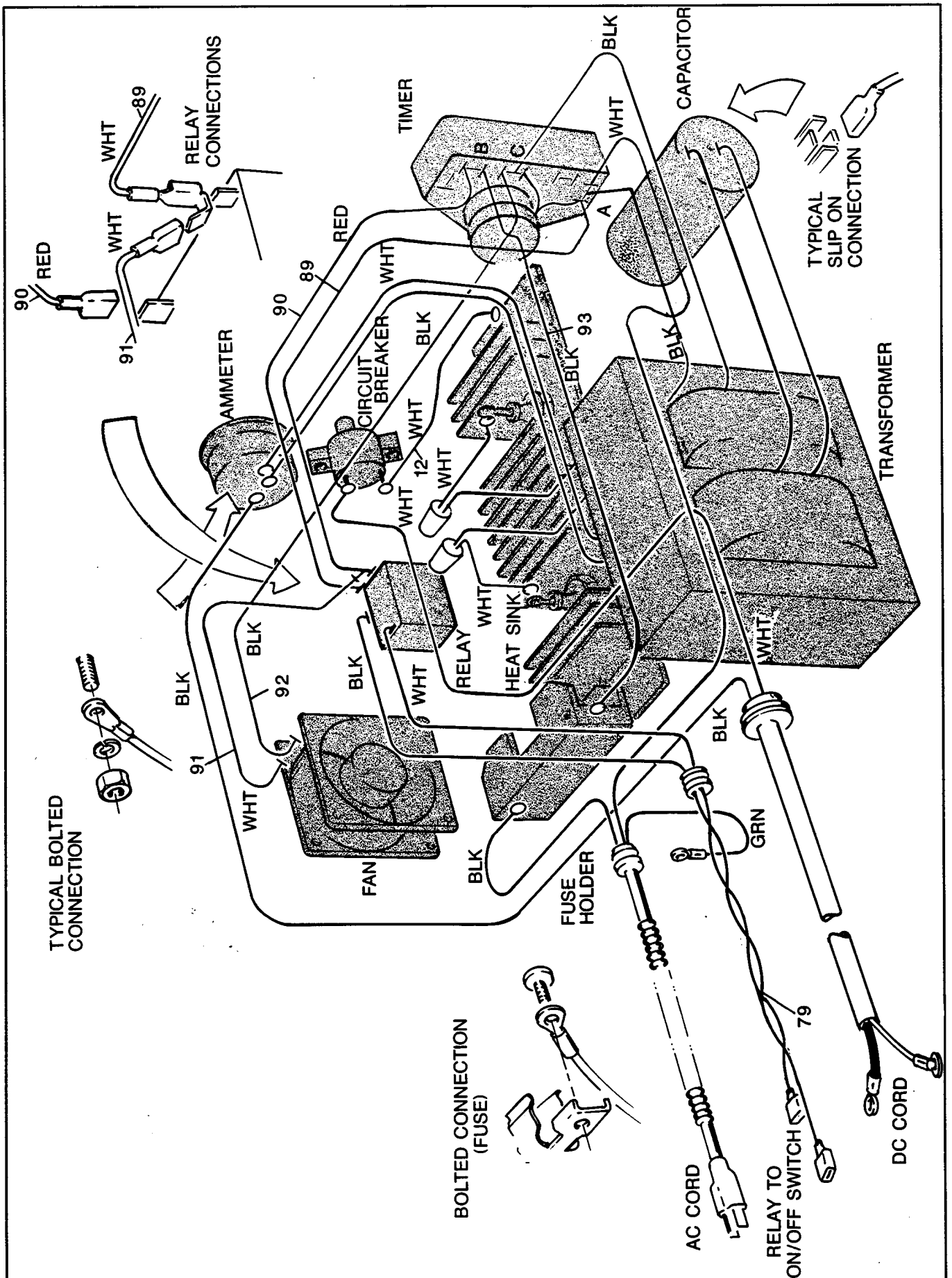

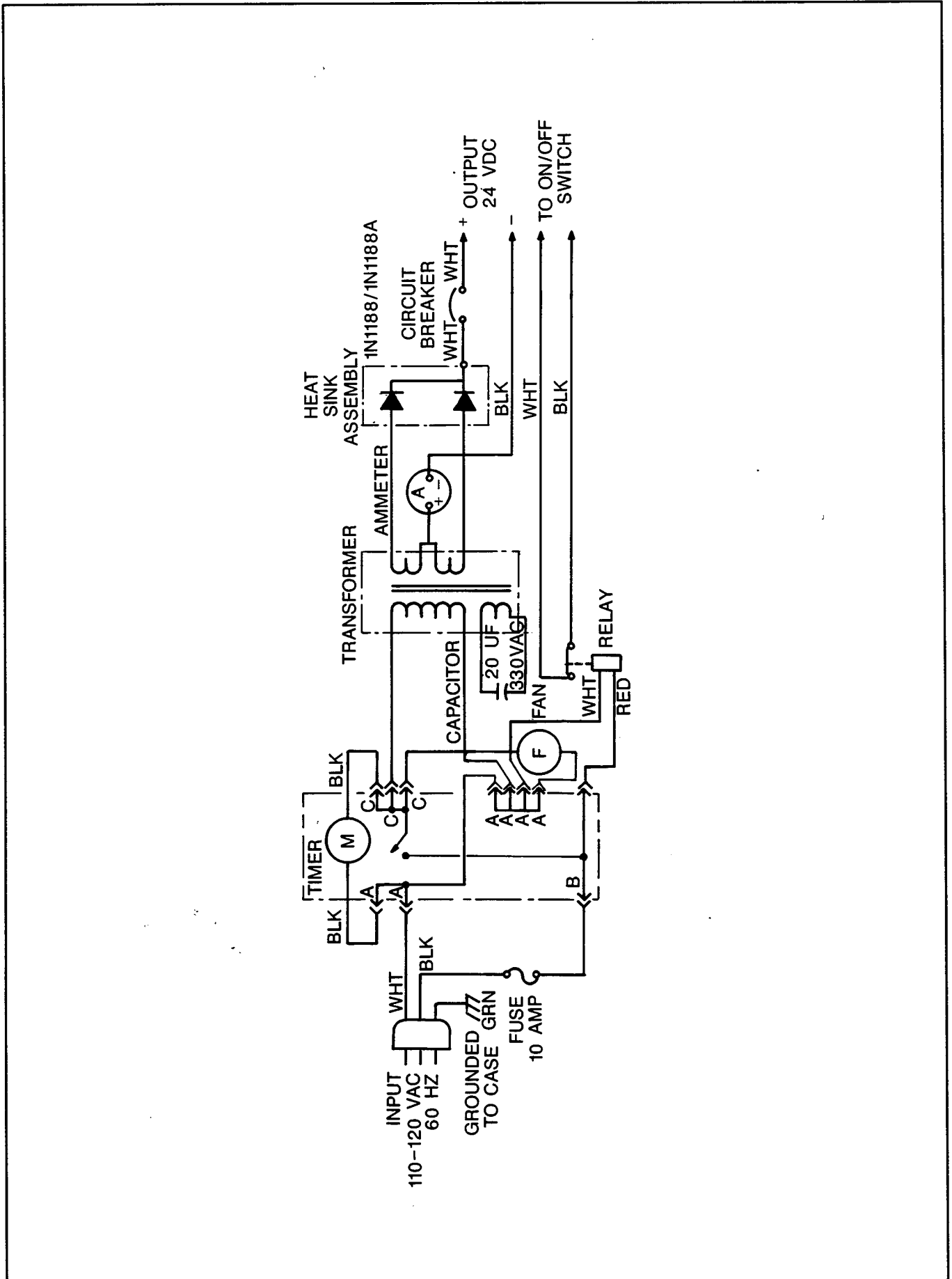

BATTERY CHARGER, ONBOARD

THE USE OF NON U.L. PARTS WILL VOID ANY U.L. LISTING.

When ordering parts, please specify the model and serial number of the product.

* Indicates a component that is not available as an individual part.

MODEL	
835	

ITEM	PART NO.	1	2	3	4	5	DESCRIPTION	QTY	
1	31883-G1						BATTERY CHARGER, ONBOARD, 24 VOLT (INCLUDES ITEMS 2 - 99)	1	
2	32495-G1						CHASSIS	1	
3	32491-G1						TRANSFORMER, 24 VOLT	1	
4	22009-G1						MOUNT, VIBRATION	4	
5	11027-G2						NUT, LOCK, 1/4 - 20	4	
6	32508-G1						HEAT SINK ASSEMBLY (INCLUDES ITEMS 7 - 15)	1	
7	32494-G1						HEAT SINK	1	
8	18488-G1						DIODE	2	
9	00567-G7						WASHER, LOCK, 1/4	2	
10	00532-G2						NUT, 1/4 - 20	2	
11	11572-G2						NUT, EXPANSION	4	
12	32509-G1						WIRE, 12 GAUGE	1	
13	00372-G4						SCREW, 10 - 24 X 1/2 LG.	1	
14	00565-G5						WASHER, LOCK, #10	1	
15	00526-G3						NUT, #10 - 24	1	
16	00512-G7						SCREW, SELF TAPPING, #8 X 7/8 LG.	4	
17									
18	32497-G1						BRACKET, FAN	1	
19	32498-G1						FAN	1	
20	00139-G2						SCREW, #6 - 32 X 1 1/4 LG.	3	
21	00565-G1						WASHER, LOCK, #6	3	
22	00525-G5						NUT, #6 - 32	3	
23	00414-G5						SCREW, 1/4 - 20 X 5/8 LG.	2	
24	11027-G2						NUT, LOCK, 1/4 - 20	2	
25	22700-G1						LABEL, FUSE	1	
26									
27	21971-G2						RELAY, SPNC	1	
28	00138-G4						SCREW, #6 - 32 X 1/2 LG.	2	
29	00559-G3						WASHER, #6	2	
30	00565-G1						WASHER, LOCK, #6	2	
31	00535-G5						NUT, #6 - 32	2	
32									
33	19362-G1						CIRCUIT BREAKER, 50 AMP (INCLUDES ITEMS 34 AND 35) ...	1	
34	00559-G3						WASHER	2	

BATTERY CHARGER, ONBOARD

THE USE OF NON U.L. PARTS WILL VOID ANY U.L. LISTING.

When ordering parts, please specify the model and serial number of the product.

* Indicates a component that is not available as an individual part.

							MODEL	
							835	
ITEM	PART NO.	1	2	3	4	5	DESCRIPTION	QTY
34	00559-G3						WASHER	2
35	00526-G4						NUT, #10 - 32	2
36	00372-G6						SCREW, #8 - 32 X 3/4 LG.	2
37	00565-G4						WASHER, LOCK, #8	2
38	00526-G1						NUT, #8 - 32	2
39								
40								
41								
42	24243-G1						AMMETER, D.C. (INCLUDES ITEM 43)	1
43							BRACKET, AMMETER	1
44	00525-G5						NUT, #6 - 32	2
45	00565-G5						WASHER, LOCK, #10	2
46	00526-G4						NUT, #10 - 32	2
47								
48								
49	32493-G1						CAPACITOR	1
50	32489-G1						BRACKET, CAPACITOR	1
51	00372-G4						SCREW, #8-32 X 1/2 LG.	2
52	00565-G4						WASHER, LOCK, #8	2
53	00526-G1						NUT, #8 - 32	2
54								
55								
56	18052-G6						TIMER	1
57	00372-G2						SCREW, #8 - 32 X 1/4 LG.	2
58	11575-G1						KNOB	1
59	00486-G4						SCREW, #8 - 32 X 1/2 LG.	1
60								
61								
62								
63	19363-G1						FUSE BLOCK	1
64	00372-G5						SCREW, #8 - 32 x 1/2 LG.	2
65	00565-G4						WASHER, LOCK, #8	2
66	00526-G1						NUT, #8 - 32	2
67	19361-G2						FUSE, 10 AMP	1

BATTERY CHARGER, ONBOARD

THE USE OF NON U.L. PARTS WILL VOID ANY U.L. LISTING.

When ordering parts, please specify the model and serial number of the product.

* Indicates a component that is not available as an individual part.

						MODEL		
						835		
ITEM	PART NO.	1	2	3	4	5	DESCRIPTION	QTY
69								
70	32499-G1						CORD, A.C.	1
71	32503-G1						CONDUIT, FLEXIBLE	1
72	16172-G1						CLAMP, NYLON	5
73	13557-G2						STRAIN RELIEF, CORD, A.C.	1
74	00372-G3						SCREW, #8 - 32 X 3/8 LG.	1
75	00565-G4						WASHER, LOCK, #8	1
76	00526-G1						NUT, #8 - 32	1
77	32500-G1						CORD, D.C.	1
78	13557-G3						STRAIN RELIEF, CORD, D.C.	1
79	32510-G1						WIRE HARNESS, CIRCUIT INTERRUPT	1
80	32502-G1						GROMMET	1
81								
82								
83	00138-G3						SCREW, #6 - 32 X 3/8 LG.	2
84	00567-G3						WASHER, LOCK, #6	2
85	00525-G5						NUT, #6 - 32	2
86								
87								
88								
89	32514-G1						WIRE, 16 GAUGE	1
90	32515-G1						WIRE, 16 GAUGE	1
91	32516-G1						WIRE, 16 GAUGE	1
92	32518-G1						WIRE, 16 GAUGE	1
93	32519-G1						WIRE, 16 GAUGE	1
94								
95								
96	32496-G1						COVER	1
97	00901-G1						NUT, CAPTIVE, 1/4 - 20	1
98								
99	00614-G4						SCREW, SELF TAPPING, #8 X 1/2 LG.	18

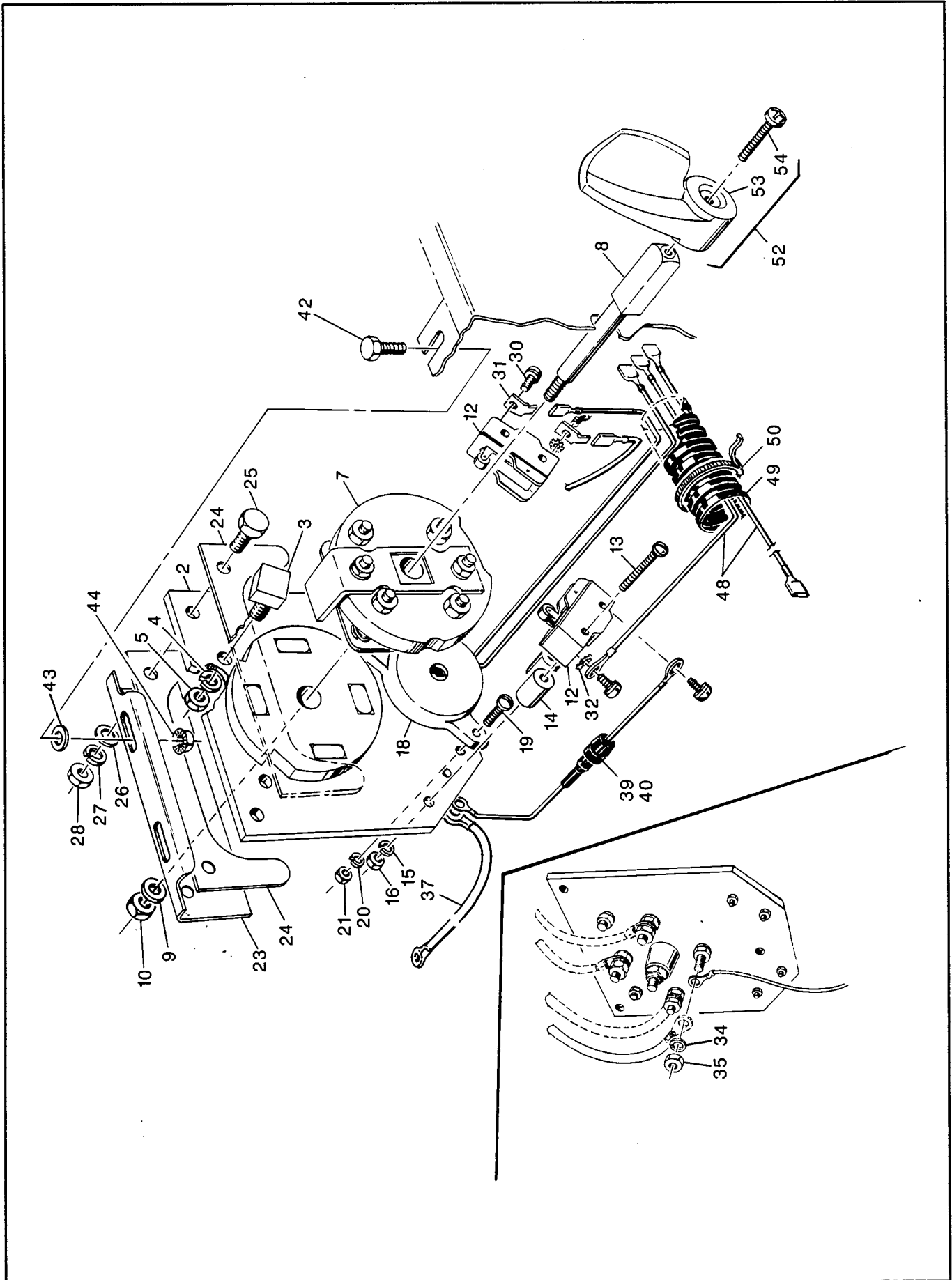

F-N-R LEVER (RESISTOR COIL AND SOLID STATE SPEED CONTROL)

THE USE OF NON U.L. PARTS WILL VOID ANY U.L. LISTING.

When ordering parts, please specify the model and serial number of the product.

* Indicates a component that is not available as an individual part.

							MODEL			
							ESC	RCV		
ITEM	PART NO.	1	2	3	4	5	DESCRIPTION		QTY	
1	25396-G3						FORWARD - NEUTRAL - REVERSE LEVER, RESISTOR COIL VERSION (INCLUDES ITEMS 3 - 50)		-	1
2	25396-G5						FORWARD - NEUTRAL - REVERSE LEVER, ELECTRONIC SPEED CONTROL (INCLUDES ITEMS 3 - 37, 42 - 50)		1	-
3	14651-G1						CONTACT BOARD ASSEMBLY		1	1
4	24940-G1						STOP		2	2
5	00565-G7						WASHER, LOCK, 1/4		2	2
6	00414-G6						SCREW, 1/4 - 20 X 3/4		2	2
7	12835-G1						F - N - R CAM ASSEMBLY		1	1
8	19470-G1						SHAFT, DIRECTION SELECTOR		1	1
9	00560-G1						WASHER, 3/8		1	1
10	14390-G1						NUT, LOCK, 3/8 - 24		1	1
11										
12	10606-G4						SWITCH, LIMIT		2	2
13	00139-G8						SCREW, #6 - 32 X 2 LG.		4	4
14	12806-G1						SPACER, LIMIT SWITCH		4	4
15	00565-G3						WASHER, LOCK, #6		4	4
16	00525-G5						NUT, #6 - 32		4	4
17										
18	17940-G1						BUZZER		1	1
19	00138-G5						SCREW, #6 - 32 X 5/8 LG.		2	2
20	00565-G3						WASHER, LOCK, #6		2	2
21	00525-G5						NUT, #6 - 32		2	2
22										
23	12863-G1						BRACKET, MOUNTING		1	1
24	15461-G1						SUPPORT, BRACKET MOUNTING		2	2
25	00415-G2						SCREW, 1/4 - 20 X 1 1/4 LG.		2	2
26	00559-G7						WASHER, 1/4		4	4
27	00565-G7						WASHER, LOCK, 1/4		2	2
28	00532-G1						NUT, 1/4 - 20		2	2
29										
30	13514-G1						SCREW, BRASS, #6 - 32 X 7/32		4	4
31	14628-G1						TAB, FASTON		2	2
32	00567-G3						WASHER, #6		1	1

F-N-R LEVER (RESISTOR COIL AND SOLID STATE SPEED CONTROL)

THE USE OF NON U.L. PARTS WILL VOID ANY U.L. LISTING.

When ordering parts, please specify the model and serial number of the product.

* Indicates a component that is not available as an individual part.

						MODEL						
						ESC	RCV					
ITEM	PART NO.	1	2	3	4	5	DESCRIPTION			QTY		
34	00565-G8						WASHER, LOCK, 5/16			4	4	
35	00544-G3						NUT, 1/4 - 20			4	4	
36												
37	23852-G3						WIRE, #6			1	1	
38												
39	32021-G1						FUSE HOLDER ASSEMBLY (INCLUDES ITEM 40)			-	1	
40	18392-G6						FUSE, 7 AMP			-	1	
41												
42	00414-G6						SCREW, 1/4 - 20 X 3/4 LG.			2	2	
43	00559-G7						WASHER, 1/4			2	2	
44	11027-G2						NUT, LOCK, 1/4 - 20			2	2	
45												
46												
47												
48	32033-G1						WIRE ASSEMBLY, F-N-R			1	1	
49	17314-G8						LOOM, FLEX			1	1	
50	17618-G1						CLAMP, NYLON			2	2	
51												
52	20325-G1						SWITCH HANDLE KIT (INCLUDES ITEMS 35 AND 36)			1	1	
53	19886-G1						HANDLE			1	1	
54	00740-G4						SCREW, #10 - 32 X 1/2 LG.			1	1	

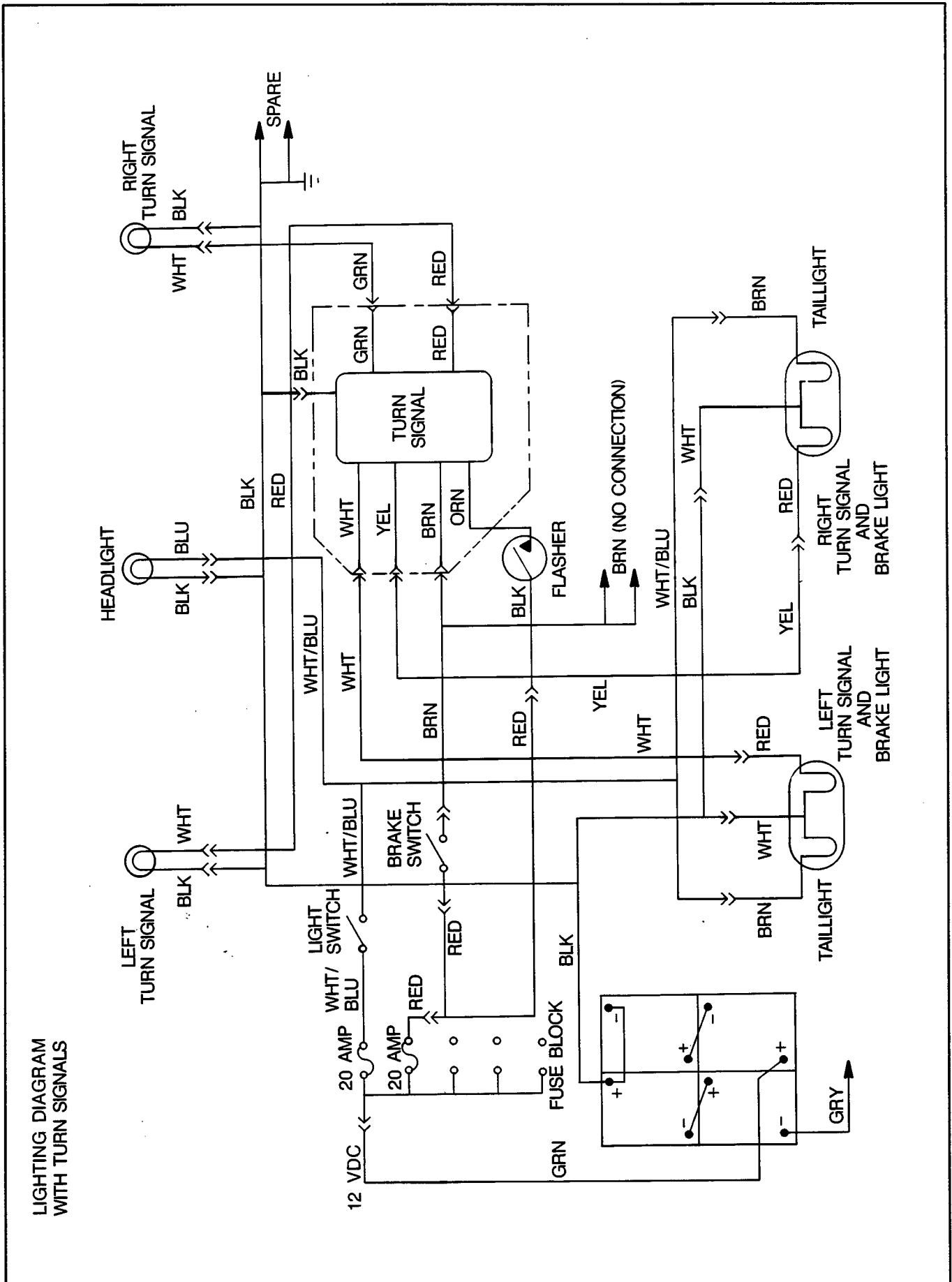

LIGHTING DIAGRAM WITH TURN SIGNALS

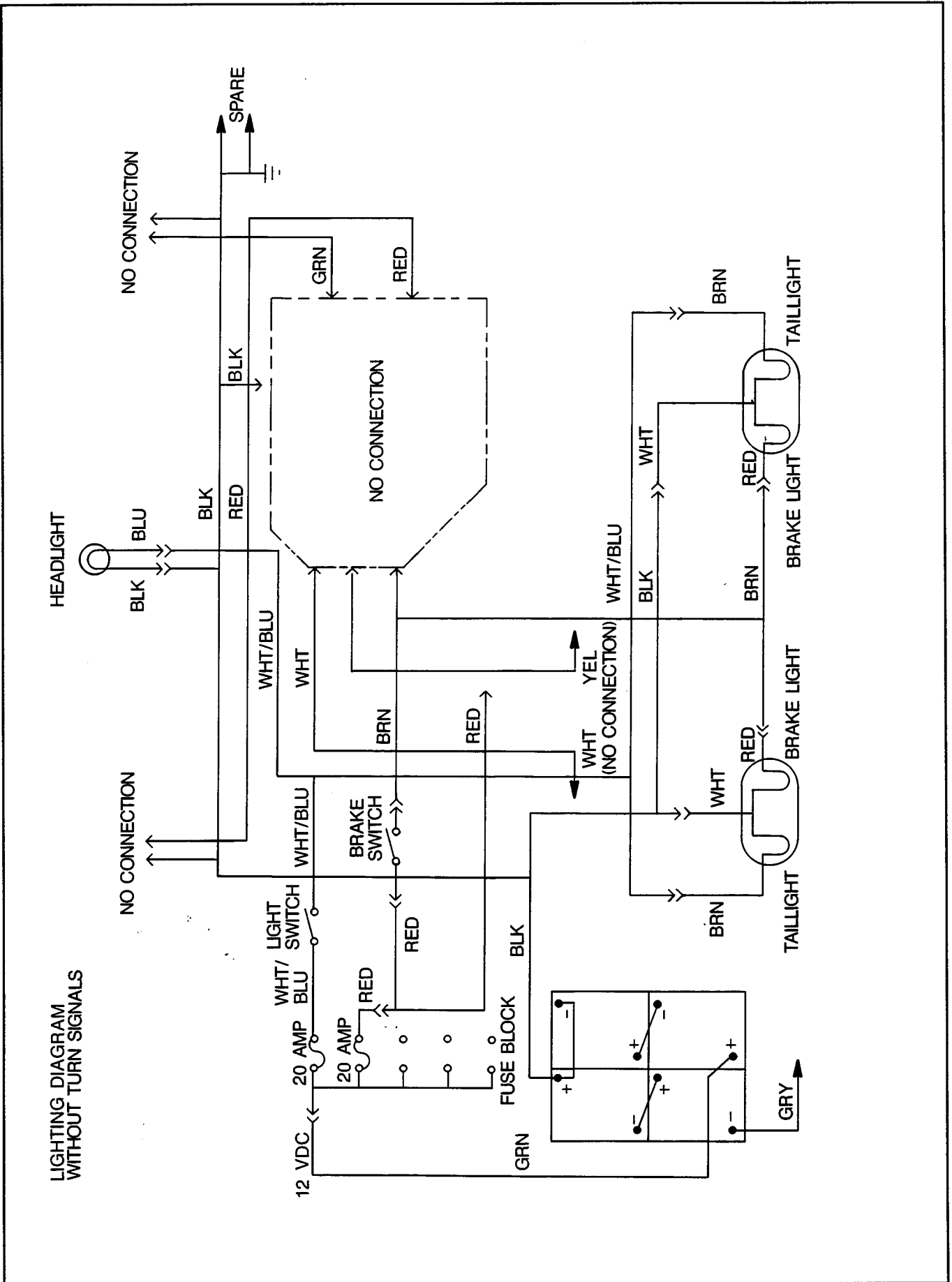

LIGHTING DIAGRAM WITHOUT TURN SIGNALS

ACCESSORY HARNESS

WHT/BLU FROM FUSE BLOCK

WHT/BLU TO HEADLIGHT/ TAILLIGHT

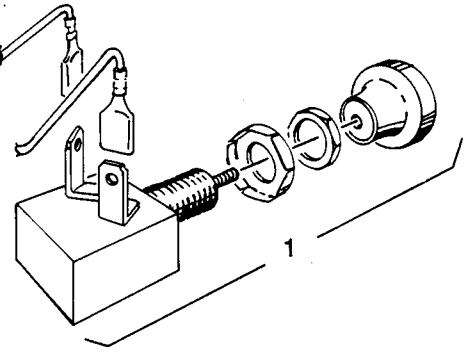

LIGHT SWITCH CONNECTIONS

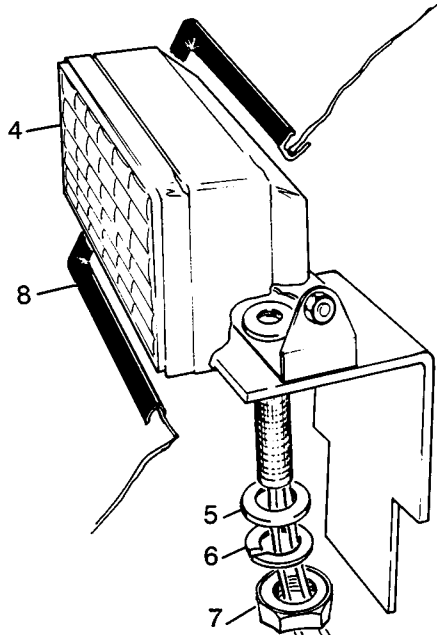

HEADLIGHT CONNECTIONS

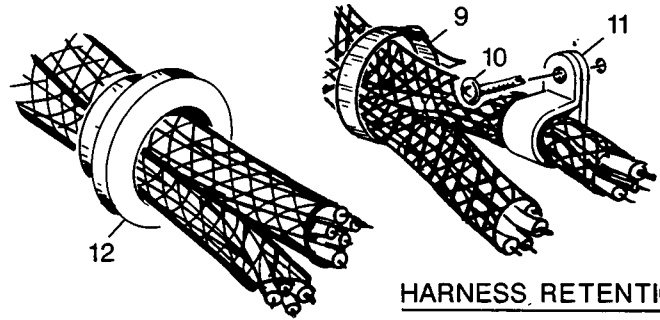

HARNESS RETENTION

BLU FROM BLU/WHT ACCESSORY HARNESS

BLK FROM BLK ACCSSORY HARNESS

GREEN TO BATTERY, STATE OF CHARGE METER AND MS-1

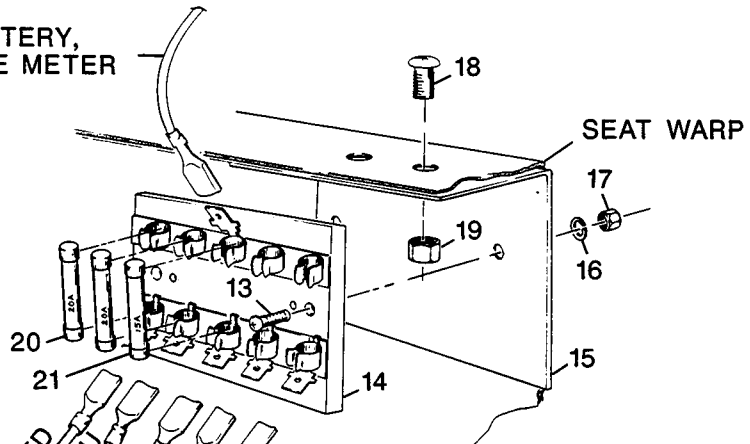

SEAT WARP

FUSE BLOCK

TO BRAKE LIGHT SWITCH
TO LIGHT SWITCH
TO HORN
SPARE +12V
SPARE +12V

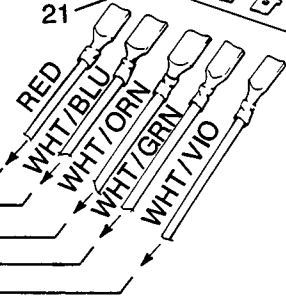

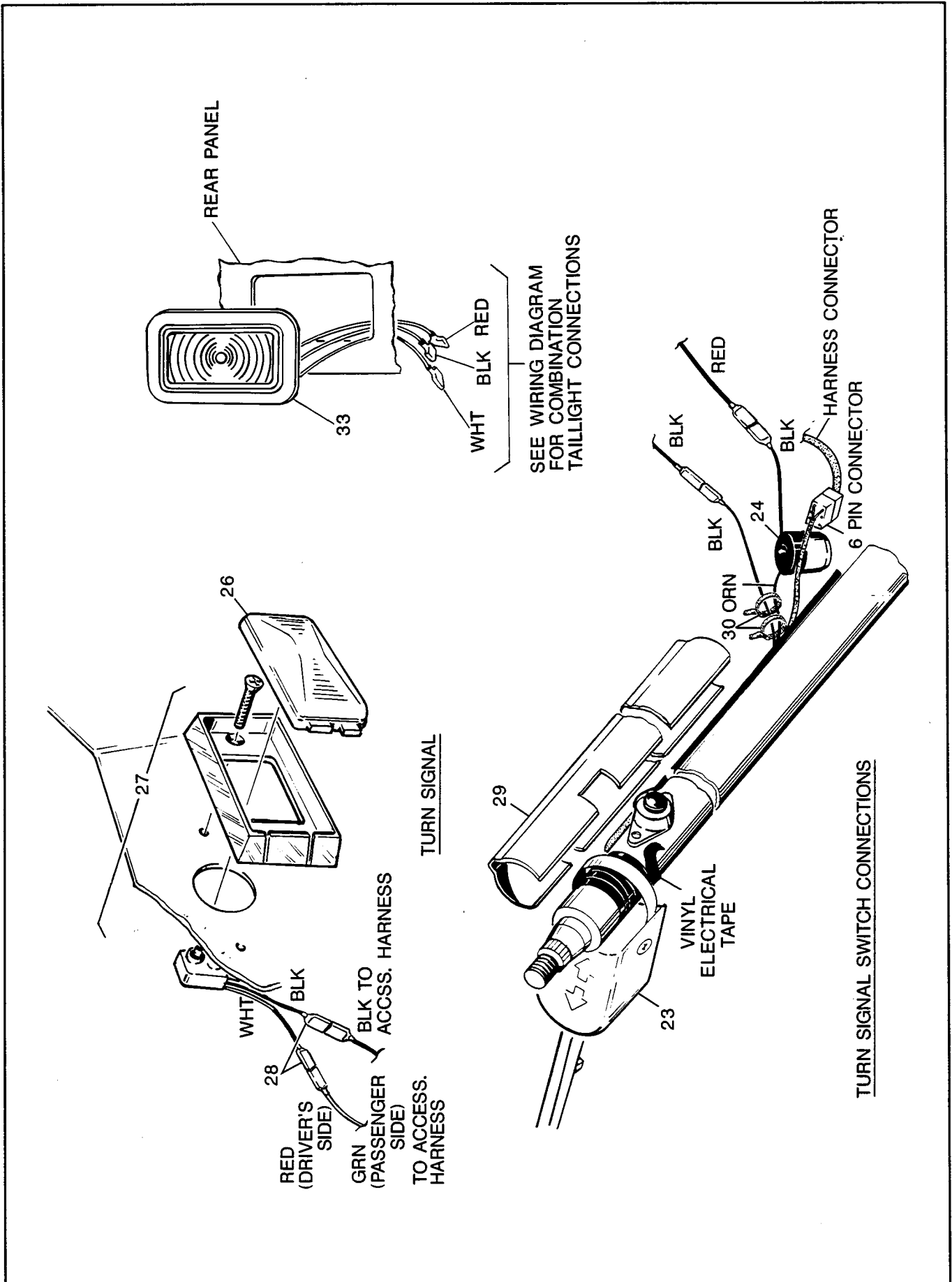

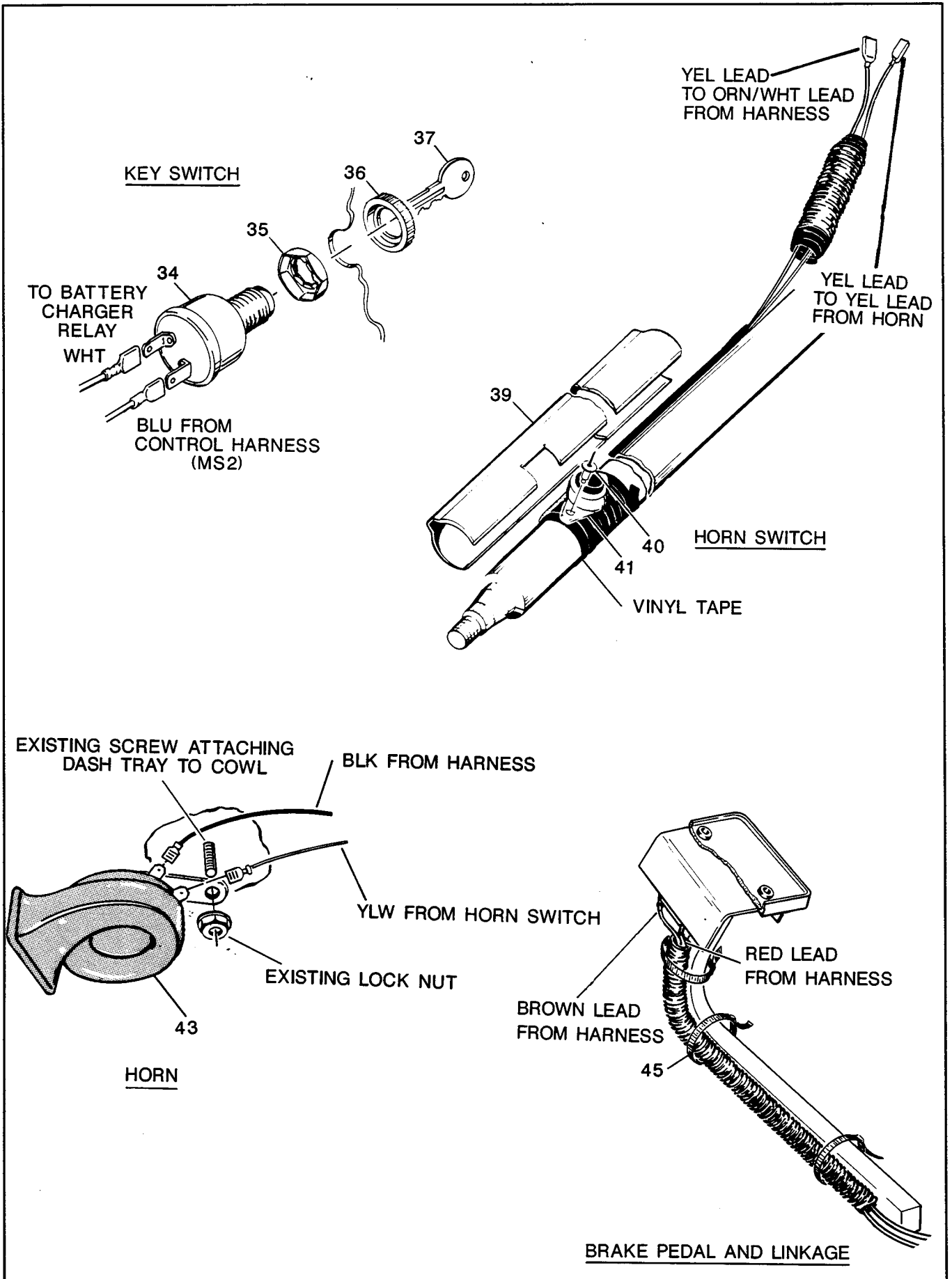

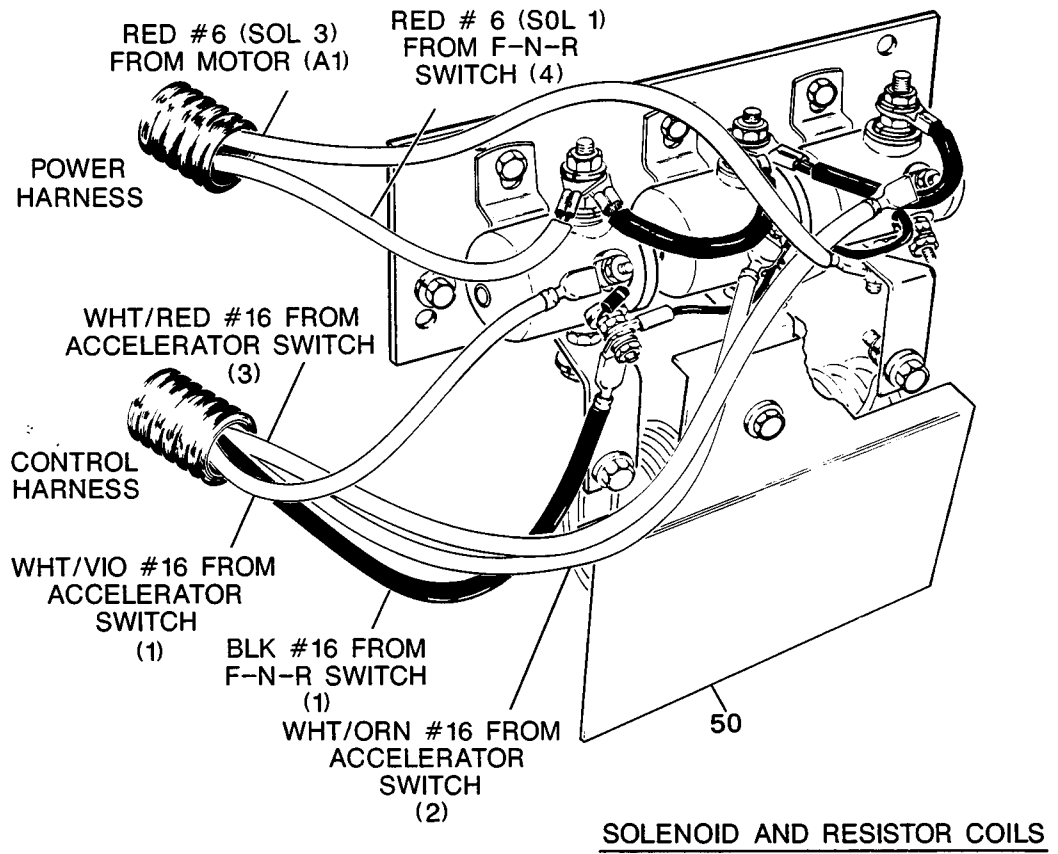
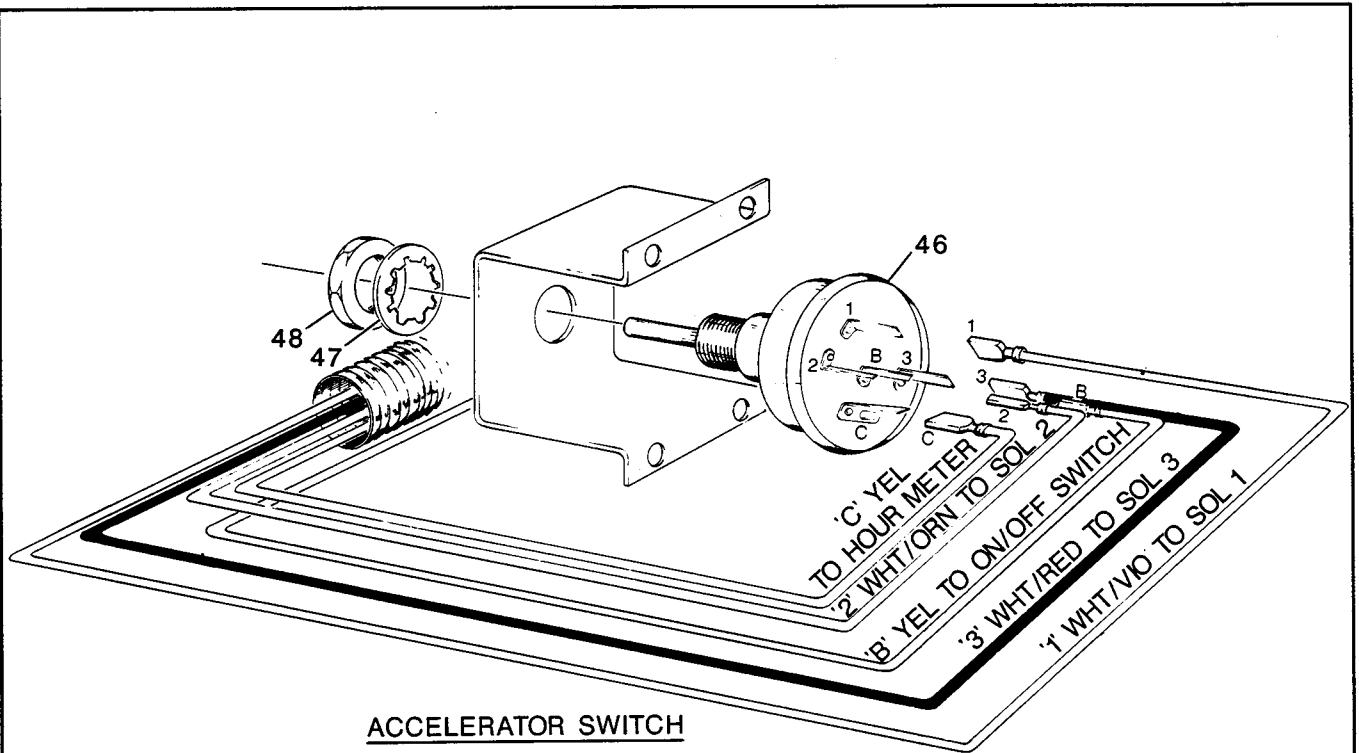

BATTERY CONNECTIONS

GREEN - FROM HARNESS

RED - TO F-N-R (3)

WHITE - TO BATTERY CHARGER

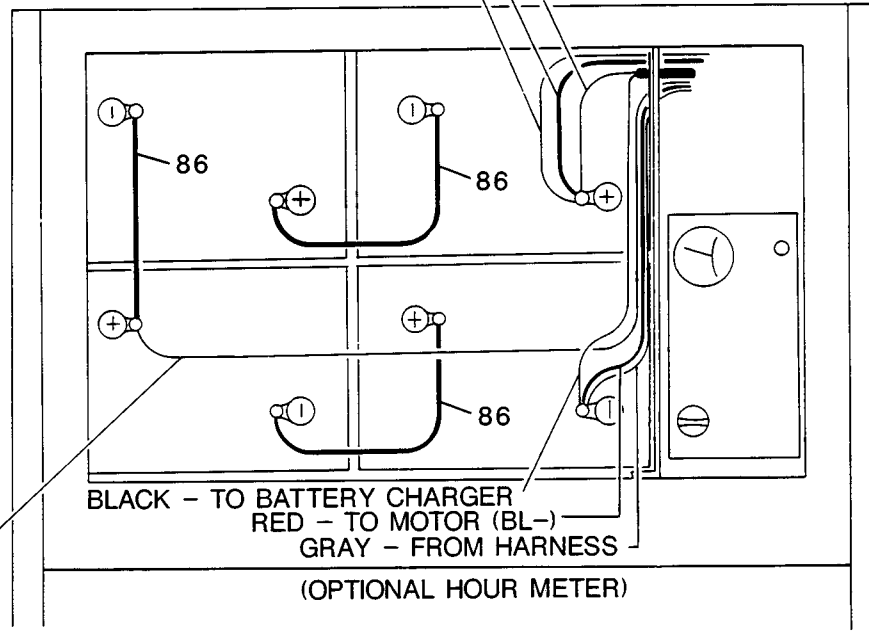

BLACK - FROM HARNESS

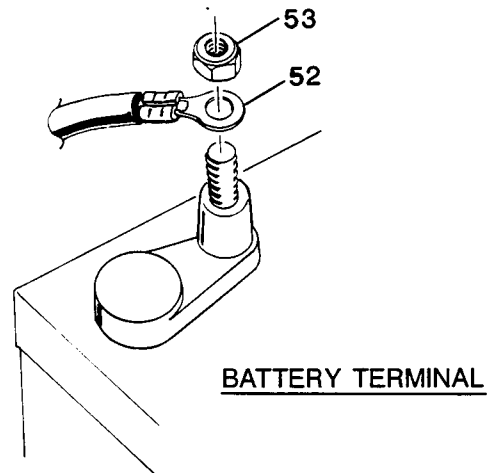
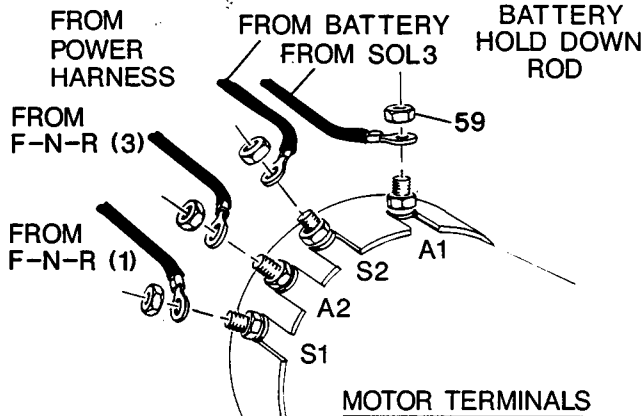
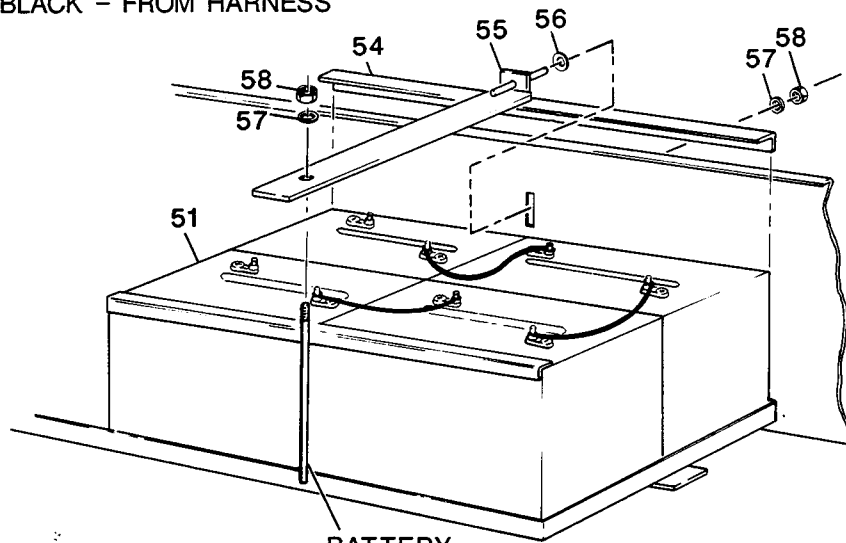

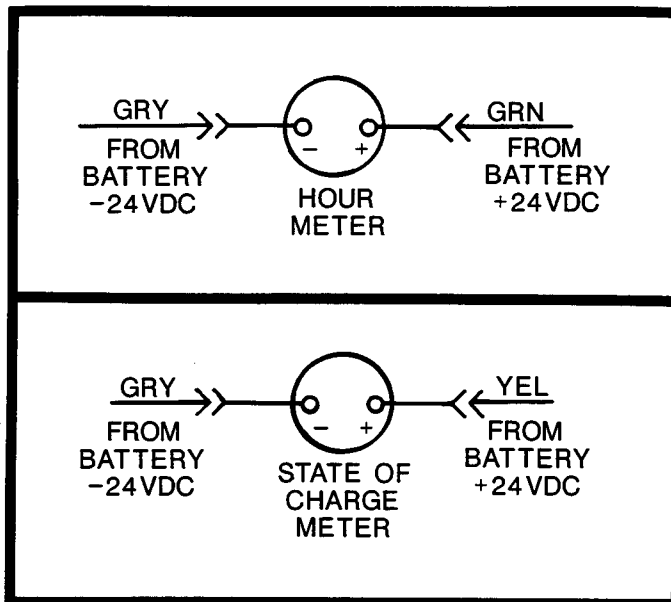
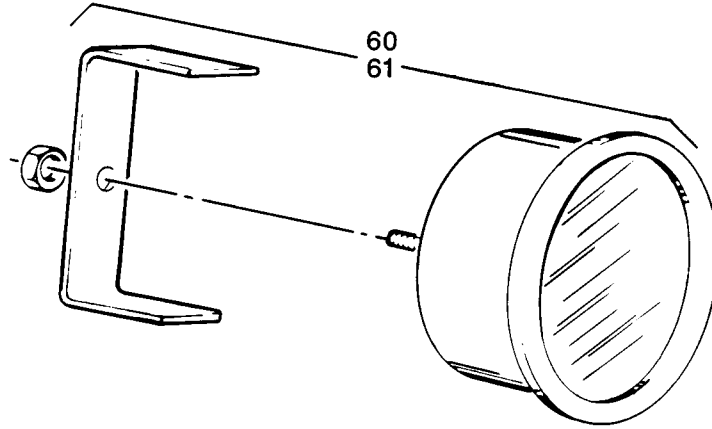

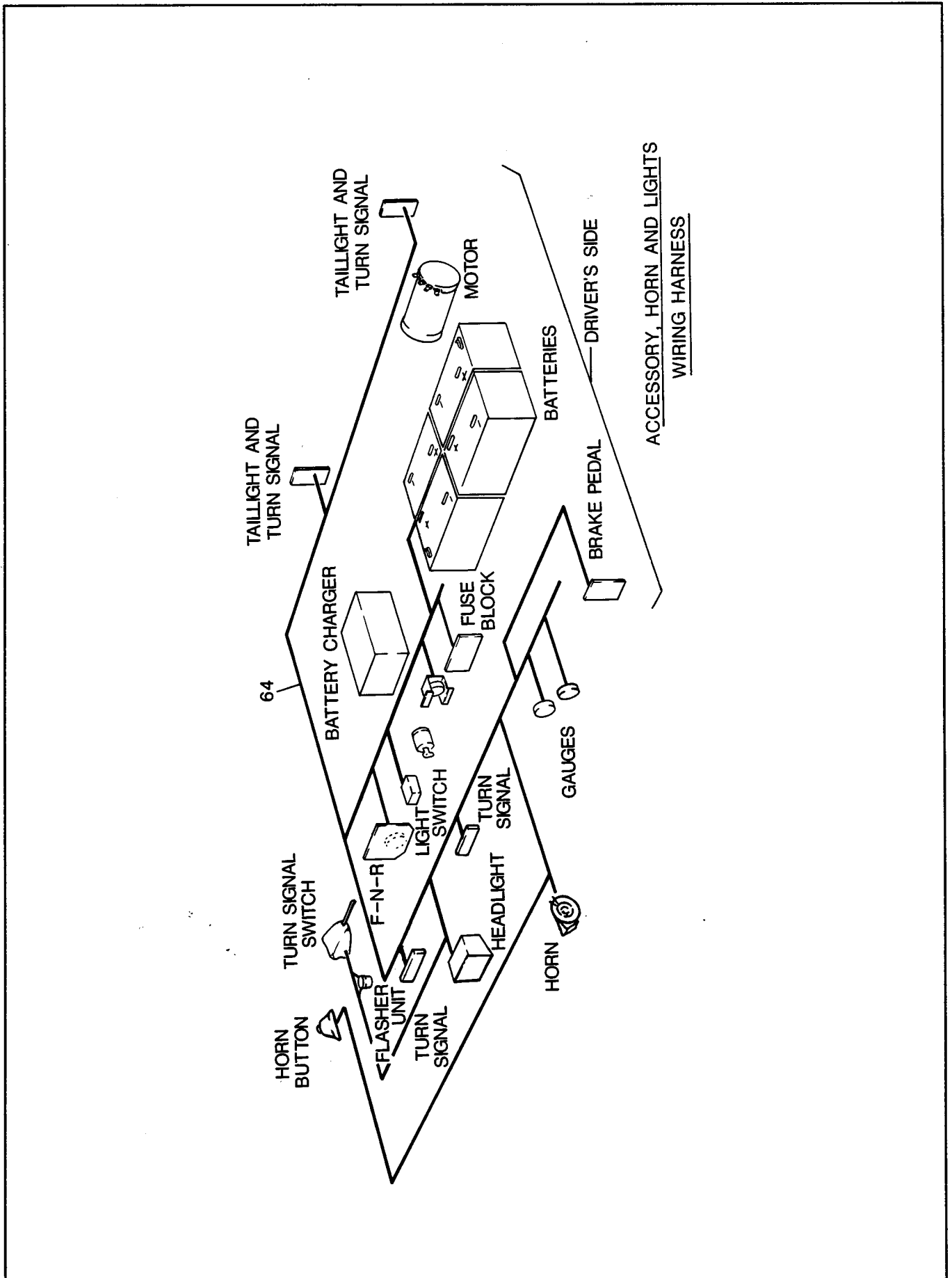

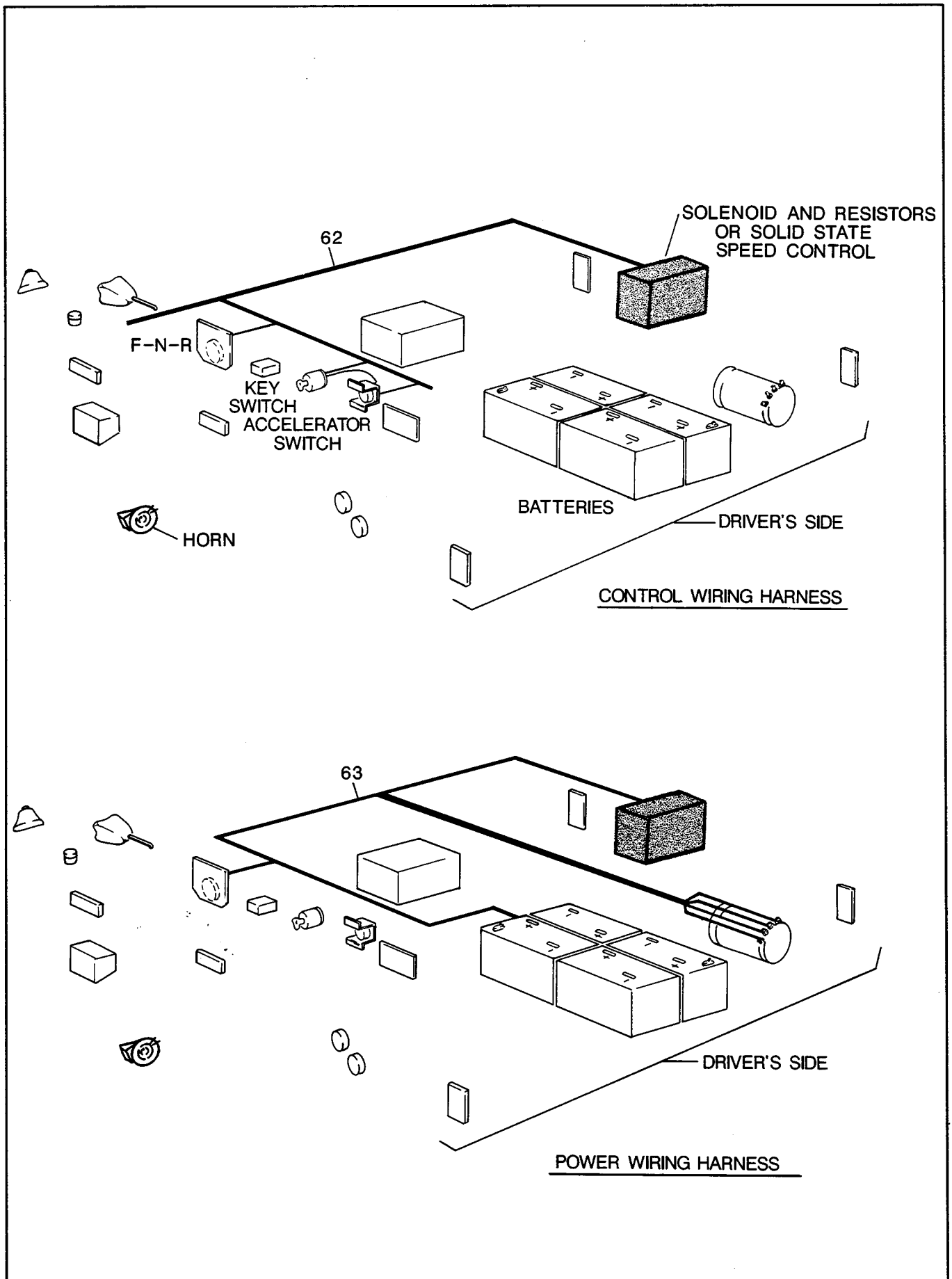

WIRING DIAGRAM

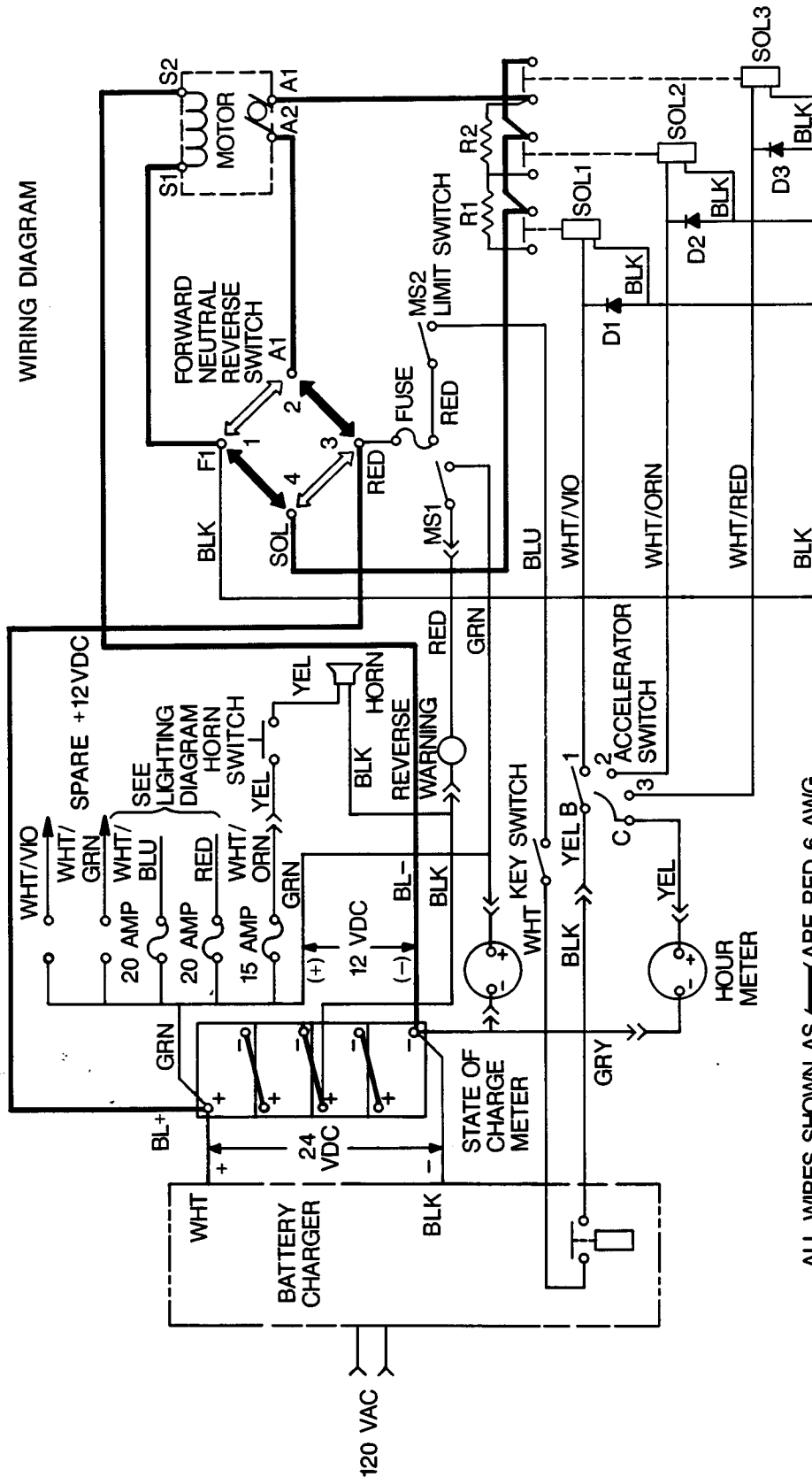

ALL WIRES SHOWN AS / ARE RED 6 AWG

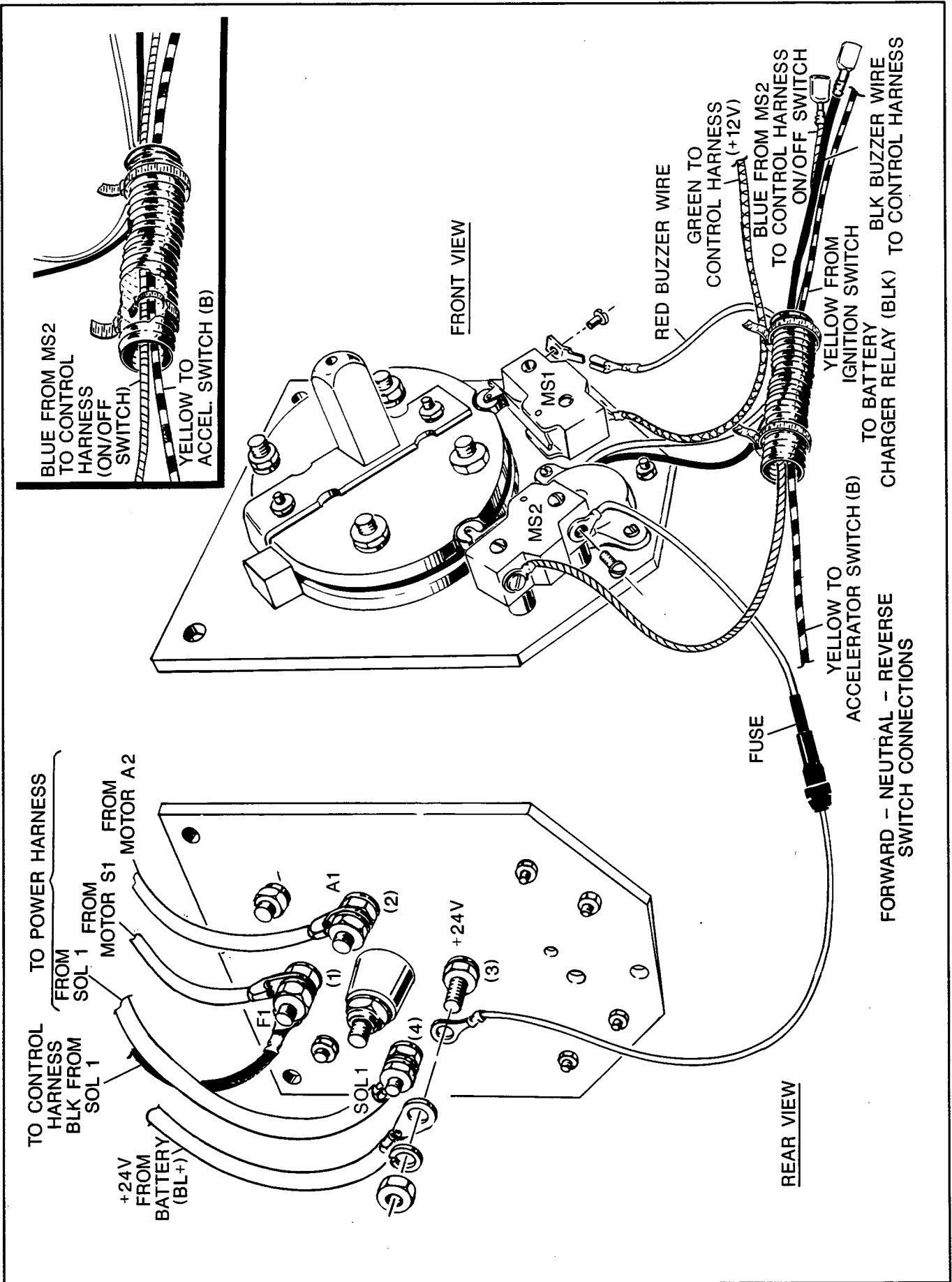

ELECTRICAL

THE USE OF NON U.L. PARTS WILL VOID ANY U.L. LISTING.

When ordering parts, please specify the model and serial number of the product.

* Indicates a component that is not available as an individual part.

						MODEL		
						835		
ITEM	PART NO.	1	2	3	4	5	DESCRIPTION	QTY
1	18431-G1						SWITCH, LIGHT (INCLUDES KNOB AND HARDWARE)	1
2								
3								
4	22523-G1						HEADLIGHT	AR
5	00560-G3						WASHER, 1/2	1
6	00566-G3						WASHER, LOCK, 1/2	1
7	00533-G1						NUT, 1/2 - 13	1
8	22280-G1						TRIM, HEADLIGHT (ORDER BY THE FOOT)	1
9	17618-G1						CLAMP, NYLON	8
10	00772-G5						SCREW, #8 X 3/4 LG.	2
11	17181-G1						CLAMP, NYLON	2
12	22497-G1						BUSHING	1
13	00138-G4						SCREW, #6 - 32 X 1/2 LG.	2
14	22674-G1						BLOCK, FUSE	1
15	22767-G1						PLATE, FUSE BLOCK	1
16	00565-G5						WASHER, LOCK, #6	2
17	00525-G5						NUT, #6 - 32	2
18	16705-G3						SCREW, STAINLESS STEEL, 1/4 - 20 X 3/4 LG.	2
19	11027-G2						NUT, LOCK, 1/4 - 20	2
20	18392-G2						FUSE, 20 AMP	2
21	18392-G1						FUSE, 15 AMP	1
22								
23	30372-G1						SWITCH, TURN SIGNAL ASSEMBLY (INCLUDES ITEM 24)	1
24	21640-G1						FLASHER, TURN SIGNAL	1
25								
26	19180-G2						BULB (REPLACEMENT)	2
27	18927-G1						ADAPTER, MOUNT KIT (INCLUDES MOUNT, SCREW AND PLUG) ..	2
28	18995-G1						TERMINAL, PUSH ON	4
29	20965-G4						COVER, STEERING COLUMN	1
30	16172-G1						CLAMP, NYLON	2
31								
32								
33	32739-G2						LAMP, STOP / TAIL	2
34	17421-G1						SWITCH, ON / OFF (INCLUDES ITEMS 35 - 37)	1

ELECTRICAL

THE USE OF NON U.L. PARTS WILL VOID ANY U.L. LISTING.

When ordering parts, please specify the model and serial number of the product.

* Indicates a component that is not available as an individual part.

							MODEL	
							835	
ITEM	PART NO.	1	2	3	4	5	DESCRIPTION	QTY
35	*						NUT, PAL	1
36	17137-G1						BEZEL	1
37	17063-G1						KEY	2
38								
39	20961-G3						COVER, STEERING WHEEL	1
40	14601-G1						RIVET	2
41	22242-G1						HORN SWITCH ASSEMBLY (COMPLETE)	1
42								
43	32860-G1						HORN (COMPLETE)	1
44								
45	16172-G1						CLAMP, NYLON	3
46	30210-G1						SWITCH, ACCELERATOR	1
47	*						WASHER, LOCK	1
48	*						NUT	1
49								
50	XXXX-XX						SOLENOID AND RESISTOR COIL ASSEMBLY (SEE SEPERATE ILLUSTRATION)	1
51	**						BATTERY, 24 VOLT	4
52	30277-G1						WIRE, 6 GAUGE	3
53	00702-G2						NUT, HEAVY, 5/16 - 18	8
54	11841-G4						HOLD DOWN , BATTERY	2
55	32087-G1						HOLD DOWN, BATTERY, CENTER	1
56	11855-G1						WASHER, FLAT, 3/8	1
57	00559-G8						WASHER, FLAT, 5/16	2
58	11098-G6						NUT, LOCK, 5/16 - 18	2
59	00532-G3						NUT, HEAVY, 5/16 - 18	4
60	21573-G1						METER, HOUR	1
61	31389-G1						METER, STATE OF CHARGE	1
62	32017-G1						HARNES, CONTROL	1
63	31851-G1						HARNES, POWER	1
64	31809-G1						HARNES, ACCESSORY, HORN AND LIGHTS	1

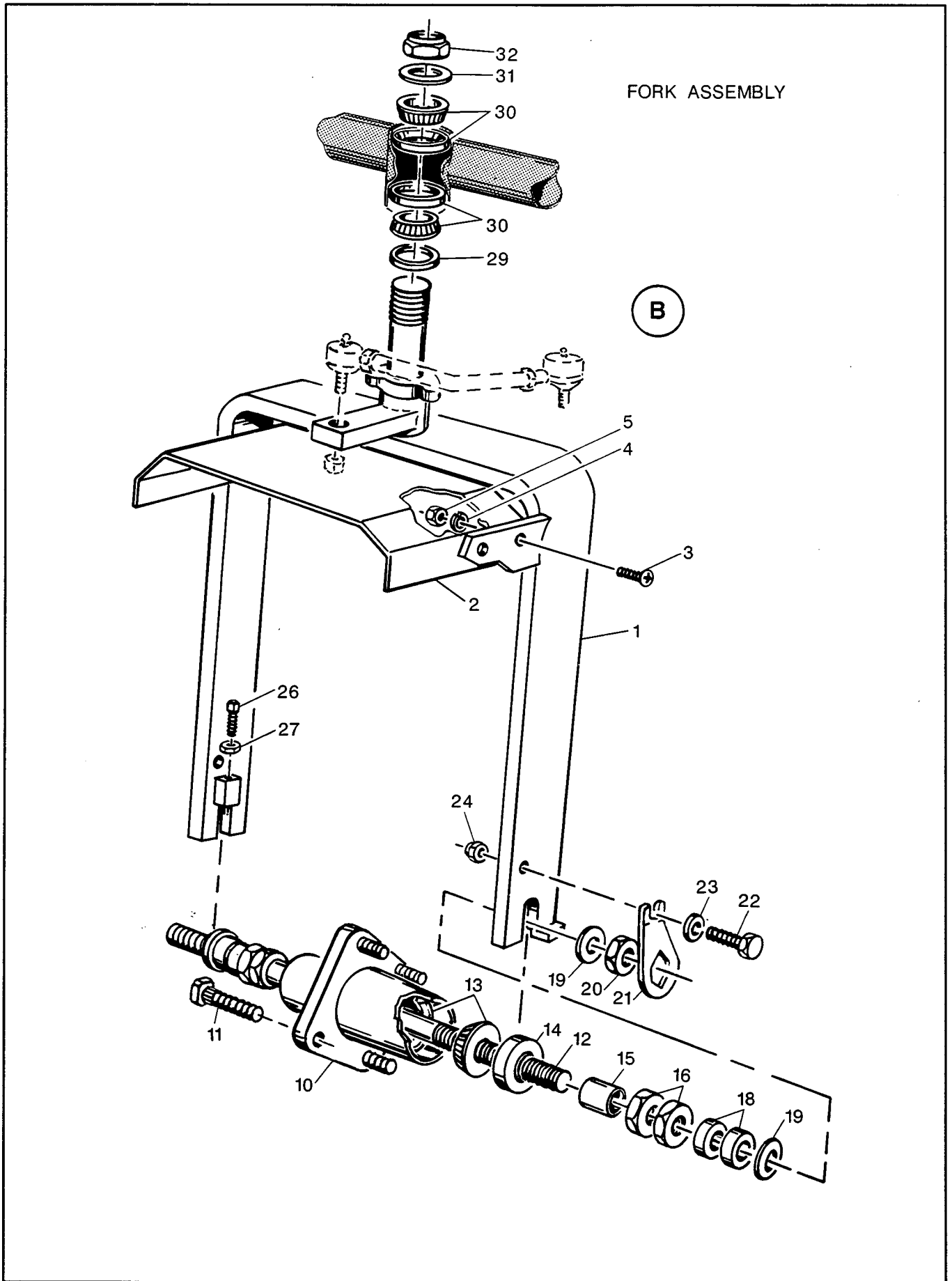

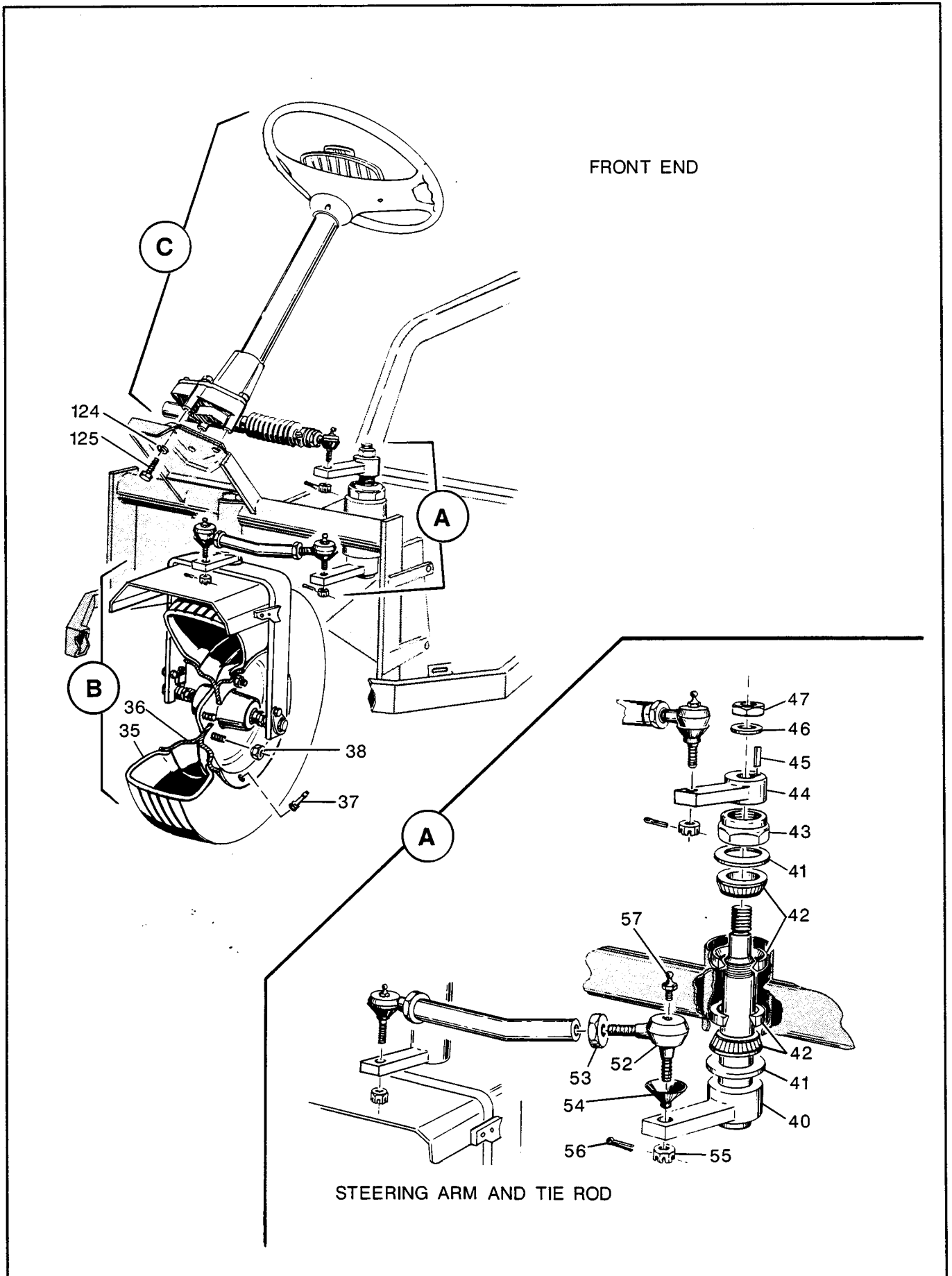

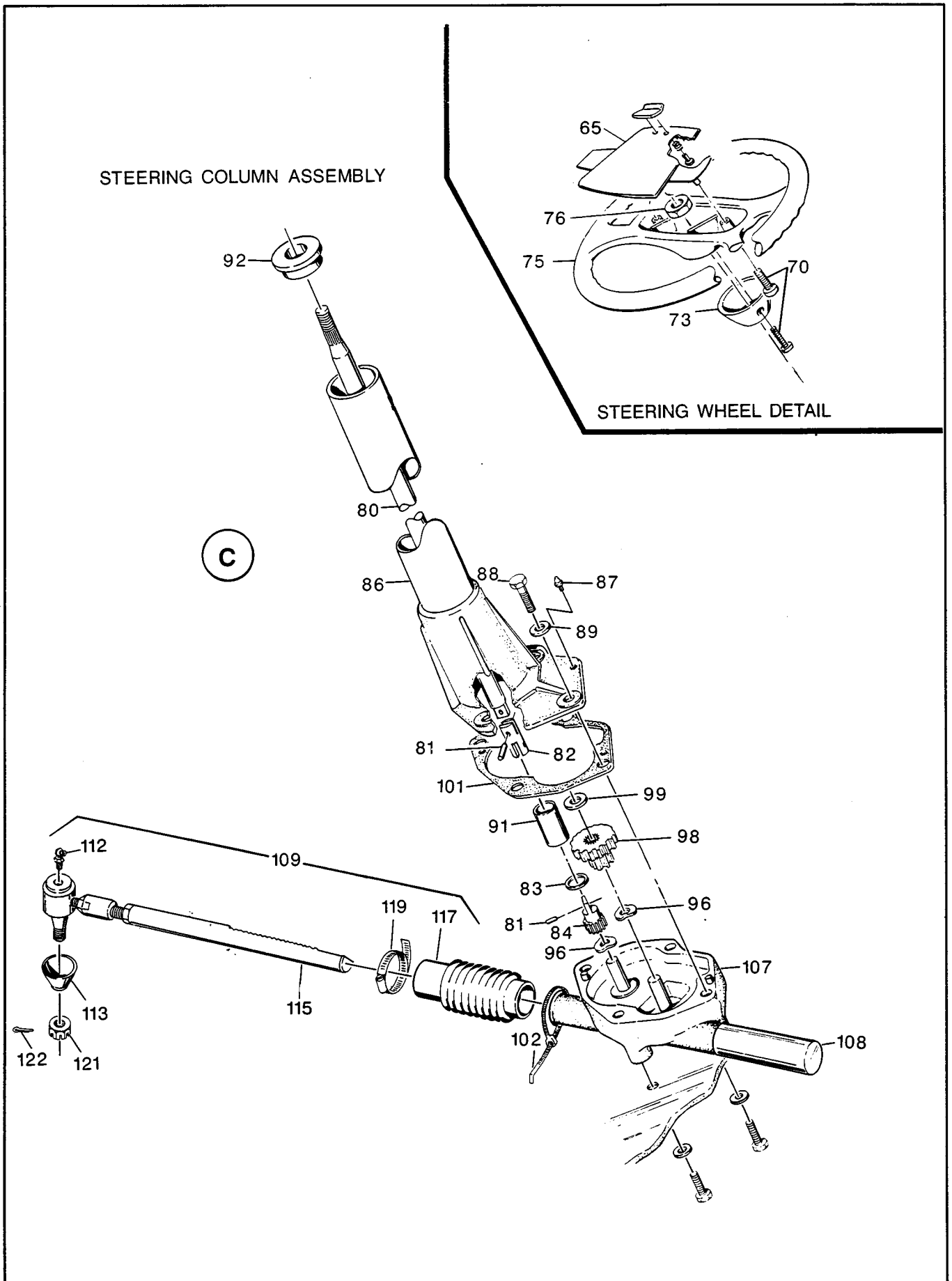

FRONT STEERING / SUSPENSION

THE USE OF NON U.L. PARTS WILL VOID ANY U.L. LISTING.

When ordering parts, please specify the model and serial number of the product.

* Indicates a component that is not available as an individual part.

						MODEL		
						835		
ITEM	PART NO.	1	2	3	4	5	DESCRIPTION	QTY
1	32342-G1						FORK	1
2	32344-G1						SHIELD	1
3	00378-G4						SCREW, #10 - 24 X 1/2 LG.	4
4	00565-G5						WASHER, LOCK, #10	4
5	00526-G3						NUT, #10 - 24	4
6								
7								
8								
9	32357-G1						HUB AND AXLE ASSEMBLY (INCLUDES ITEMS 10 - 16)	1
10	19888-G1						HUB ASSEMBLY (INCLUDES BEARING RACE AND ITEM 11) ..	1
11	19862-G1						BOLT, WHEEL, 1/2 - 20 X 1 1/2 LG.	4
12	10223-G6						AXLE, FRONT	1
13	11750-G1						BEARING, ROLLER, 3/4 SPINDLE	2
14	19471-G1						SEAL, GREASE	2
15	11655-G1						SPACER, FRONT AXLE	2
16	00667-G8						NUT, STAINLESS STEEL, 3/4 - 16	4
17								
18	17650-G2						RING, ADJUSTER, STAINLESS STEEL	4
19	00560-G6						WASHER, FLAT, 3/4	4
20	00673-G1						NUT, LOCK, STAINLESS STEEL, 3/4 - 16	2
21	18256-G2						RETAINER, AXLE NUT	2
22	00665-G2						SCREW, STAINLESS STEEL, 3/8 - 16 X 1 LG.	2
23	00679-G1						WASHER, FLAT, STAINLESS STEEL, 3/8	2
24	00654-G1						NUT, LOCK, STAINLESS STEEL, 3/8 - 16	2
25								
26	00655-G4						SCREW, STAINLESS STEEL, 1/4 - 20 X 1 1/2 LG.	2
27	00656-G1						NUT, STAINLESS STEEL, 1/4 - 20	2
28								
29	13136-G1						SPACER	1
30	13756-G1						BEARING, ROLLER, COMPLETE	2
31	10669-G3						WASHER, SPECIAL	1
32	11098-G1						NUT, LOCK, 1 3/8 - 12	1
33								
34	30421-G1						TIRE AND WHEEL ASSEMBLY (INCLUDES ITEMS 35 - 37)	1

FRONT STEERING / SUSPENSION

THE USE OF NON U.L. PARTS WILL VOID ANY U.L. LISTING.

When ordering parts, please specify the model and serial number of the product.

* Indicates a component that is not available as an individual part.

							MODEL	
							835	
ITEM	PART NO.	1	2	3	4	5	DESCRIPTION	QTY
35	30422-G1						TIRE, 4.80 X 8	1
36	19350-G1						RIM, WHEEL	1
37	11657-G1						STEM, VALVE	1
38	14723-G1						NUT, LUG, 1/2 - 20	4
39								
40	32287-G1						ARM, STEERING	1
41	10669-G3						WASHER, SPECIAL	2
42	13756-G1						BEARING, ROLLER, COMPLETE	2
43	11098-G1						NUT, LOCK, 1 3/8 - 12	1
44	32289-G1						ARM, PITMAN	1
45	21230-G1						KEY, 1/4 X 1/4 X 7/8 LG.	1
46	00566-G5						WASHER, LOCK, 5/8	1
47	14390-G7						NUT, LOCK, 5/8 - 11	1
48								
49								
50								
51	20795-G2						TIE ROD END (INCLUDES ITEMS 52 - 56)	2
52	:						TIE ROD END, R.H.	1
53	18434-G2						NUT, R.H. THREAD, 9/16 - 18	1
54	50641-G1						RUBBER BOOT	1
55	50209-G1						NUT, SLOTTED, 7/16 - 20	1
56	10387-G2						COTTER, PIN, 3/16 X 1 LG.	1
57	10389-G3						FITTING, GREASE	2
58								
59								
60								
61								
62								
63								
64								
65	27102-G1						PLATE, SCORECARD HOLDER ASSEMBLY	1
66								
67								
68								

FRONT STEERING / SUSPENSION

THE USE OF NON U.L. PARTS WILL VOID ANY U.L. LISTING.

When ordering parts, please specify the model and serial number of the product.

* Indicates a component that is not available as an individual part.

							MODEL	
							835	
ITEM	PART NO.	1	2	3	4	5	DESCRIPTION	QTY
69								
70	18464-G1						SCREW, SELF TAPPING, # 8 X 7/8 LG.	4
71								
72								
73	23225-G1						HUB, COVER EXTENSION	1
74								
75	23172-G1						STEERING WHEEL	1
76	14390-G2						NUT, 5/8 X 18	1
77								
78	19152-G2						STEERING UNIT ASSEMBLY (INCLUDES ITEMS 80 - 119)	1
79								
80	:						SHAFT, STEERING	1
81	:						PIN, DOWEL, 1/4	2
82	:						COUPLING	1
83	13059-G1						WASHER, THRUST	1
84	13048-G1						PINION, STEERING	1
85								
86	19153-G3						STEERING COLUMN ASSEMBLY	1
87	13098-G1						FITTING, GREASE	1
88	00448-G8						SCREW, 5/16 - 24 X 1 LG.	4
89	00565-G8						WASHER, LOCK, 5/16	4
90								
91	17140-G1						SLEEVE	1
92	17161-G1						BUSHING AND SEAL ASSEMBLY	1
93								
94								
95								
96	51294-G1						WASHER, WAVE TYPE SPRING	2
97								
98	23279-G1						GEAR, REDUCTION	1
99	13059-G2						WASHER, THRUST	1
100								
101	19154-G1						GASKET, HOUSING	1
102	17618-G1						CLAMP, NYLON	1

FRONT STEERING / SUSPENSION

THE USE OF NON U.L. PARTS WILL VOID ANY U.L. LISTING.

When ordering parts, please specify the model and serial number of the product.

* Indicates a component that is not available as an individual part.

MODEL	
835	

ITEM	PART NO.	1	2	3	4	5	DESCRIPTION	QTY	
103									
104									
105									
106									
107	13097-G1						HOUSING ASSEMBLY (INCLUDES ITEM 108)		1
108	13570-G2						COVER, RACK		1
109	15407-G1						RACK AND ROD ASSEMBLY (INCLUDES ITEMS 112 - 119) ...		1
110									
111									
112	18456-G1						FITTING, GREASE		1
113	50641-G1						RUBBER BOOT, TIE ROD END		1
114									
115	*						RACK, STEERING		1
116									
117	17617-G1						BELLOWS		1
118									
119	11391-G1						CLAMP, HOSE		1
120									
121	50209-G1						NUT, SLOTTED, 7/16 - 20		1
122	10387-G2						PIN, COTTER, 3/16 X 1 LG.		1
123									
124	00276-G6						SCREW, 5/16 - 24 X 3/4 LG.		3
125	00565-G8						WASHER, LOCK, 5/16		3

FRONT STEERING

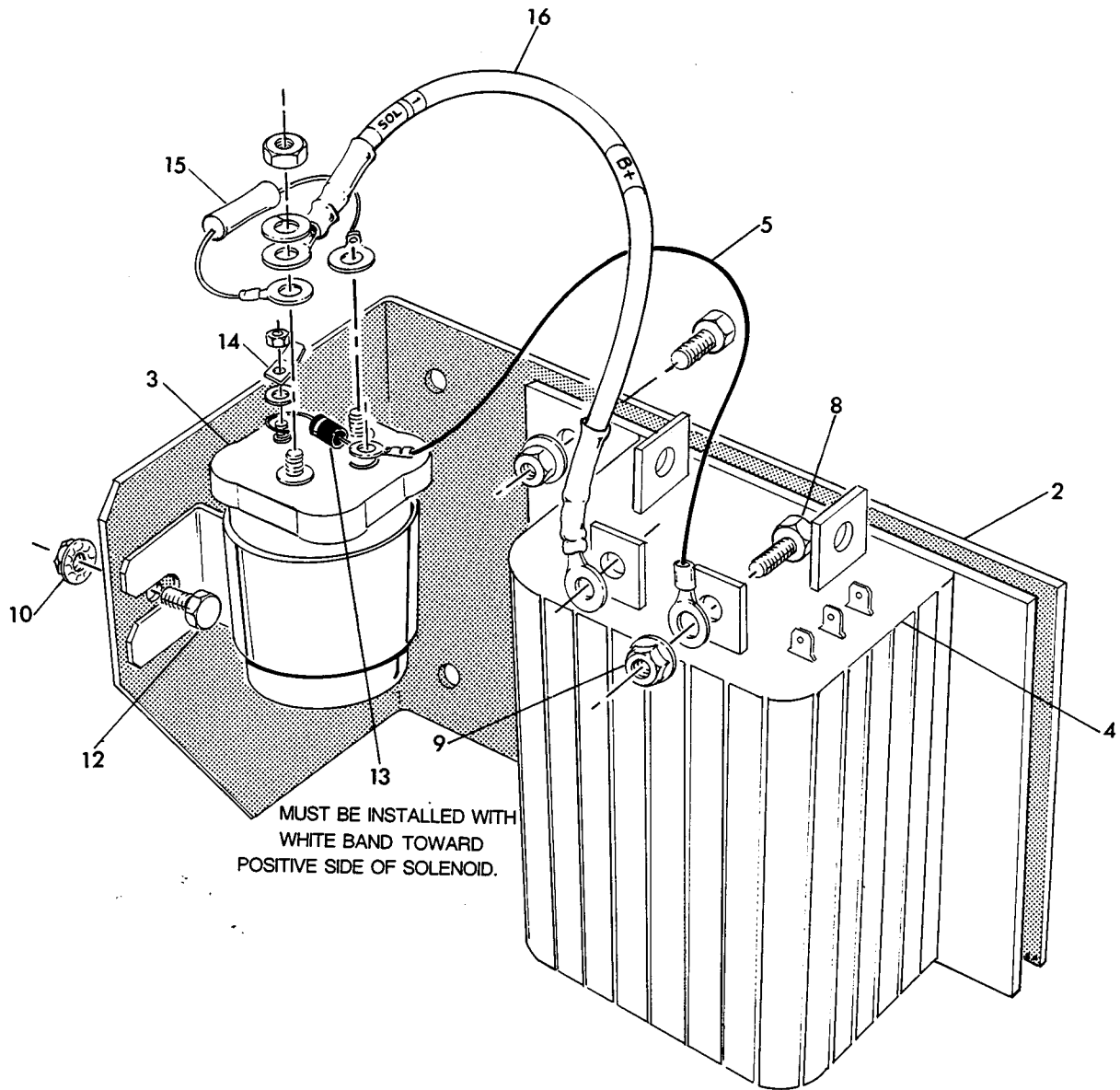

ELECTRONIC SPEED CONTROL

THE USE OF NON U.L. PARTS WILL VOID ANY U.L. LISTING.

When ordering parts, please specify the model and serial number of the product.

* Indicates a component that is not available as an individual part.

MODEL	
835	

ITEM	PART NO.	1	2	3	4	5	DESCRIPTION	QTY	
1	24000-G1						CONTROL BOX AND SOLENOID ASSEMBLY (INCLUDES ITEMS 2 - 15)	1	
2	23634-G1						SUPPORT, LDI	1	
3	20468-G3						SOLENOID, HEAVY DUTY, 24 VOLT	1	
4	20972-G1						SPEED CONTROL, LDI	1	
5	24021-G1						WIRE ASSEMBLY, 16 GAUGE	1	
6									
7	00270-G5						SCREW, 5/16 - 18 X 5/8 LG.	2	
8	11027-G1						NUT, LOCK, 5/16 - 18	2	
9	11027-G2						NUT, LOCK, 1/4 - 20	4	
10									
11	00414-G5						SCREW, 1/4 - 20 X 5/8 LG.	4	
12	30353-G1						DIODE	1	
13	12914-G1						TAB, FASTON	1	
14	21764-G1						RESISTOR ASSEMBLY	1	
15	23959-G9						WIRE ASSEMBLY	1	

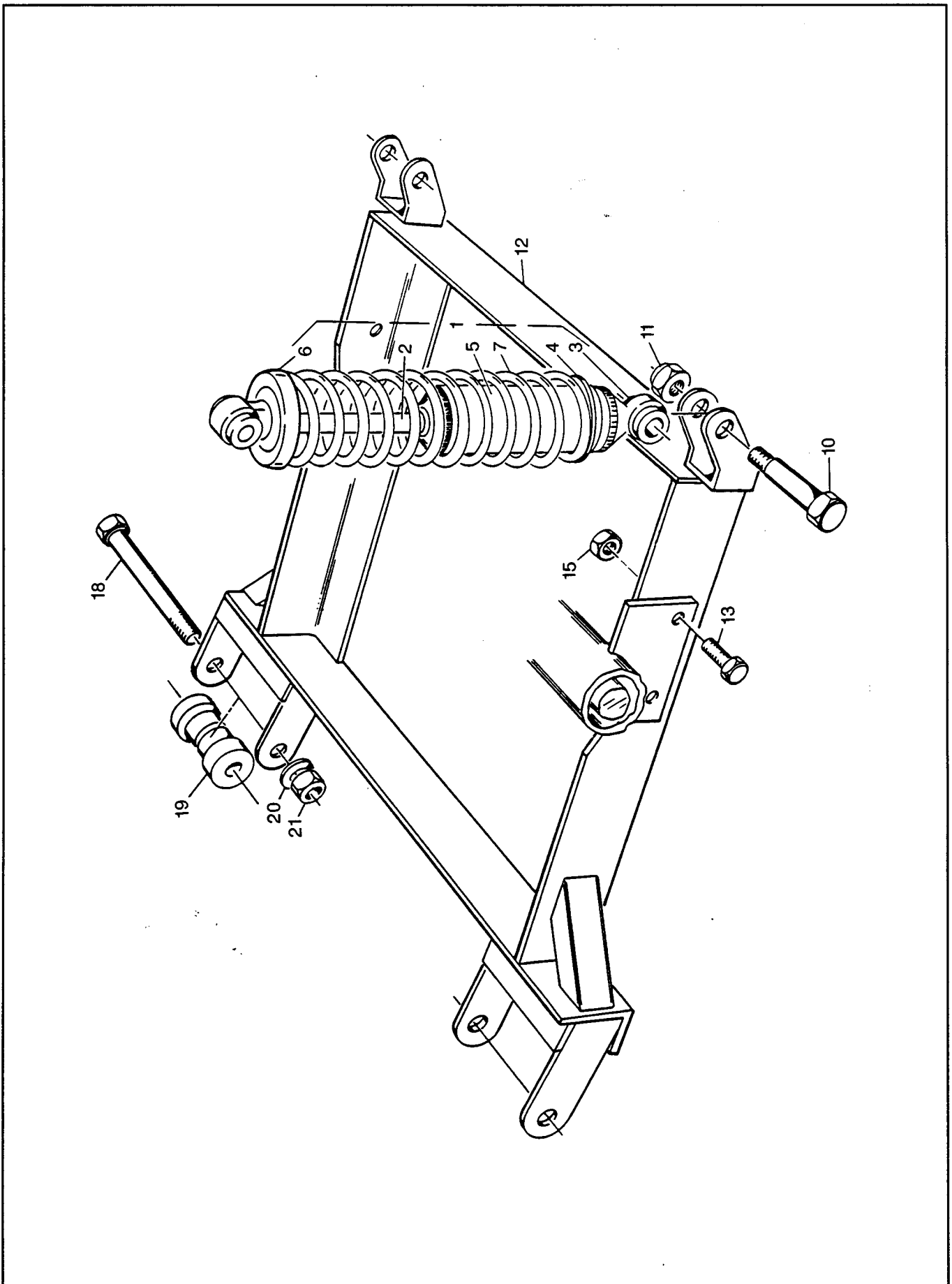

INNER FRAME AND SUSPENSION

THE USE OF NON U.L. PARTS WILL VOID ANY U.L. LISTING.

When ordering parts, please specify the model and serial number of the product.

* Indicates a component that is not available as an individual part.

MODEL	
835	

ITEM	PART NO.	1	2	3	4	5	DESCRIPTION	QTY	
1	21297-G1						SHOCK ABSORBER ASSEMBLY	2	
2	21784-G1						SHOCK ABSORBER	1	
3	21779-G1						BUSHING	2	
4	15593-G1						RING	1	
5	15992-G1						SLEEVE	1	
6	15595-G1						RETAINER, SPRING	1	
7	23917-G2						SPRING, COMPRESSION	1	
8									
9									
10	15589-G1						BOLT, SHOULDER, 1/2 - 20	4	
11	11098-G8						NUT, LOCK, 1/2 - 20	4	
12	32608-G1						FRAME, INNER	1	
13	00427-G2						SCREW, 3/8 - 16 X 1 LG.	4	
14									
15	11098-G5						NUT, 3/8 - 16	4	
16									
17									
18	00405-G8						SCREW, 1/2 - 13 X 4 LG.	2	
19	32639-G1						BUSHING	4	
20	00566-G3						WASHER, LOCK, 1/2	2	
21	00551-G1						NUT, LOCK, 1/2 - 13	2	

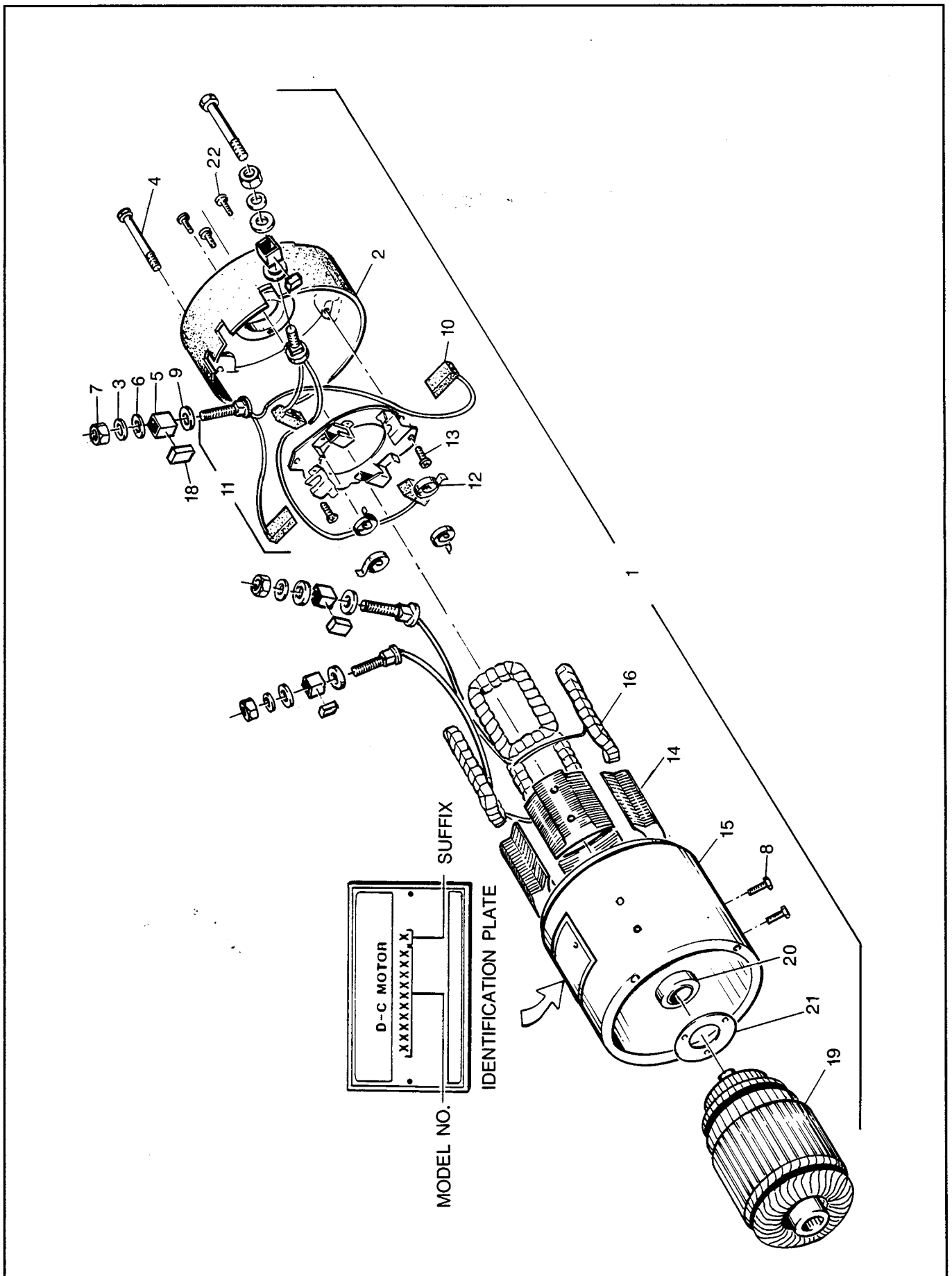

MOTOR, 2 H.P.

THE USE OF NON U.L. PARTS WILL VOID ANY U.L. LISTING.

When ordering parts, please specify the model and serial number of the product.

: Indicates a component that is not available as an individual part.

							MODEL	
							835	
ITEM	PART NO.	1	2	3	4	5	DESCRIPTION	QTY
1	22858-G1						MOTOR, 2 H.P.	1
2	16922-G1						ENDSHIELD, COMMUTATOR END	1
3	13483-G1						WASHER	4
4	16919-G1						SCREW, MOTOR CLAMP	2
5	15437-G1						BUSHING, INSULATOR	4
6	15438-G1						WASHER, INSULATOR	4
7	15440-G1						NUT, LOCK	4
8	23234-G1						SCREW, POLE PIECES	8
9	15442-G1						WASHER, INSULATOR, TERMINAL	4
10	16917-G1						BRUSH ASSEMBLY	2
11	16916-G1						BRUSH RIGGING	1
12	15446-G1						SPRING, BRUSH	4
13	51333-G1						SCREW, BRUSH RIGGING MOUNT	2
14	*						FIELD POLE PIECES	4
15	*						SHELL, STATOR	1
16	23235-G1						COILS, FIELD (SET)	1
17								
18	16948-G1						GASKET	4
19	*						ARMATURE	1
20	16918-G1						BALL BEARING, COMMUTATOR END	1
21	16930-G1						RETAINER, BEARING	1
22	23236-G1						SCREW, BEARING RETAINER	3

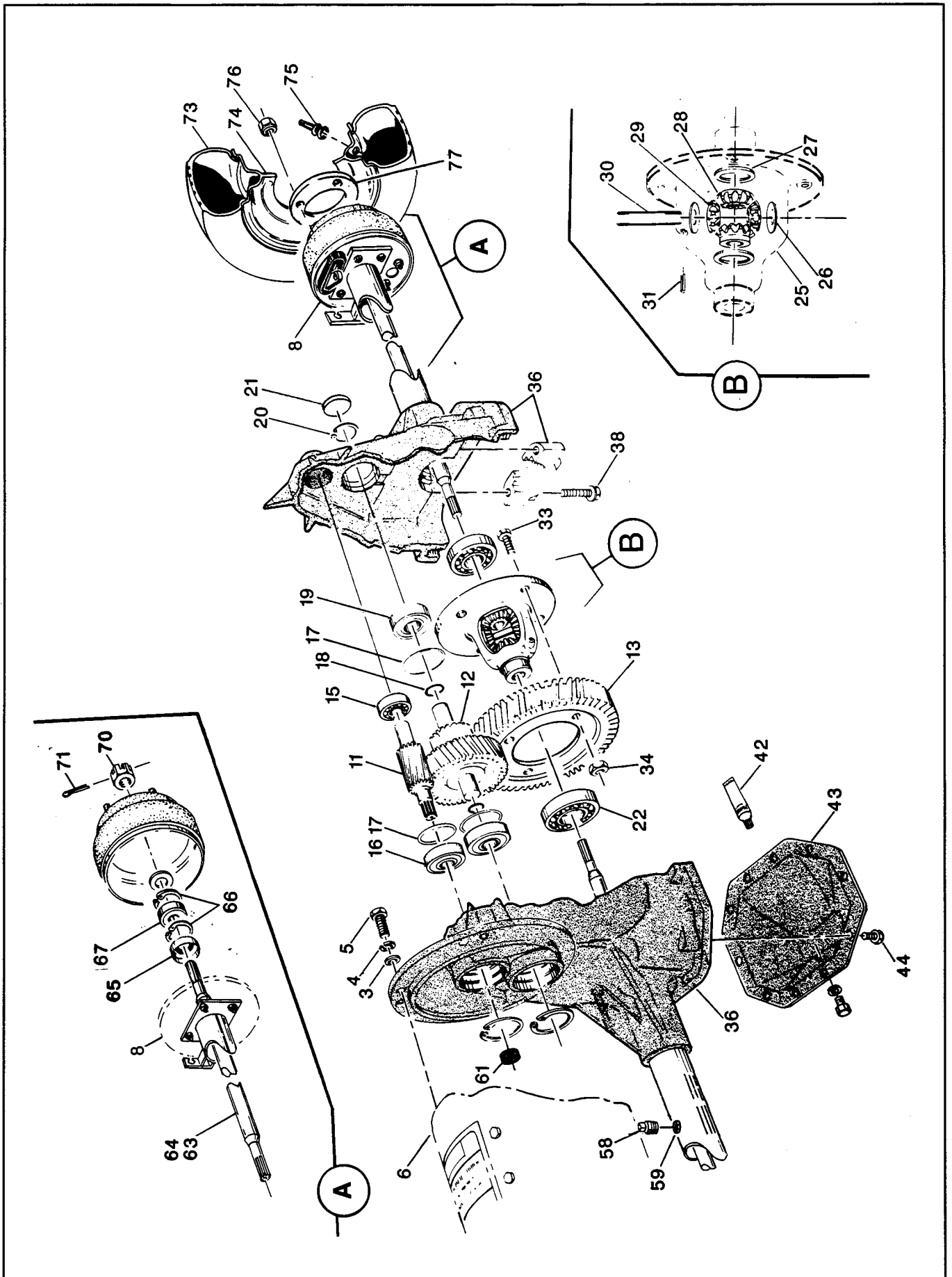

REAR AXLE

THE USE OF NON U.L. PARTS WILL VOID ANY U.L. LISTING.

When ordering parts, please specify the model and serial number of the product.

* Indicates a component that is not available as an individual part.

							MODEL	
							835	
ITEM	PART NO.	1	2	3	4	5	DESCRIPTION	QTY
1	31972-G2	REAR AXLE, MOTOR AND BRAKE ASSEMBLY (INCLUDES ITEMS 3 - 71)						1
2								
3	00559-G7	WASHER, 1/4						3
4	00565-G7	WASHER, LOCK, 1.4						3
5	00797-G2	SCREW, 1/4 - 20 X 1 1/4 LG.						3
6	XXXXX-XX	MOTOR, 2 H.P. (SEE MOTOR SECTION)						1
7	25283-G13	REAR AXLE AND BRAKE ASSEMBLY (INCLUDES ITEMS 8 - 59, 70, 71)						1
8	XXXXX-XX	BRAKE SET (SEE WHEEL BRAKE ASSEMBLY SECTION) ..						1
9	31841-G2	REAR AXLE ASSEMBLY (INCLUDES ITEMS 10 - 71)						1
10	23501-G2	GEAR SET (INCLUDES ITEMS 11 - 13)						1
11	26927-G01	GEAR, INPUT						1
12	23501-G2	GEAR, INTERMEDIATE						1
13	20376-G2	GEAR, OUTPUT						1
14								
15	23520-G1	BALL BEARING, INPUT GEAR						1
16	23519-G1	BALL BEARING, INPUT GEAR, INTERMEDIATE						1
17	23525-G1	SEAL, O-RING						3
18	23526-G1	SEAL, O-RING						2
19	23521-G1	BALL BEARING, INTERMEDIATE GEAR						2
20	23530-G1	RETAINING RING						3
21	23531-G1	COVER, DUST						1
22	17473-G1	BALL BEARING, OUTPUT GEAR						2
23								
24	18463-G1	DIFFERENTIAL ASSEMBLY (INCLUDES ITEMS 25 - 31) ...						1
25	*	CASE, DIFFERENTIAL						1
26	13106-G1	WASHER, THRUST PINION GEAR						2
27	13104-G1	WASHER, THRUST DIFFERENTIAL GEAR						2
28	18060-G1	GEAR, DIFFERENTIAL						2
29	13105-G1	GEAR, PINION						2
30	13107-G1	SHAFT, PINION GEAR						1
31	13102-G1	PIN, LOCKING						1
32								

REAR AXLE

THE USE OF NON U.L. PARTS WILL VOID ANY U.L. LISTING.

When ordering parts, please specify the model and serial number of the product.

* Indicates a component that is not available as an individual part.

MODEL		
	835	

ITEM	PART NO.	1	2	3	4	5	DESCRIPTION	QTY		
34	00532-G6						NUT, 3/8 - 24		4	
35										
36	*						AXLE HOUSING (INCLUDES ITEM 38)		1	
37										
38	15118-G1						SCREW, 3/8 - 16 X 2 1/8 LG.		4	
39										
40										
41										
42	20536-G1						SEALANT (ENOUGH FOR ONE APPLICATION)		1	
43	23527-G1						PLATE, COVER		1	
44	15558-G1						SCREW, 5/16 - 18 X 3/4 LG.		10	
45										
46										
47										
48										
49										
50										
51										
52										
53										
54										
55										
56										
57	23826-G1						KIT, VENT PLUG (INCLUDES ITEMS 58,59)		1	
58	19039-G1						VALVE, VENT		1	
59	23827-G1						BUSHING, REDUCER		AR	
60										
61	24261-G1						SPLINE, BUMPER		1	
62										
63	20377-G5						SHAFT, AXLE, L.H.		1	
64	20377-G6						SHAFT, AXLE, R.H.		1	
65	15114-G1						SEAL, AXLE		2	
66	15113-G1						RETAINING, RING		4	
67	15112-G1						BALL BEARING AXLE, AXLE		2	

REAR AXLE

THE USE OF NON U.L. PARTS WILL VOID ANY U.L. LISTING.

When ordering parts, please specify the model and serial number of the product.

* Indicates a component that is not available as an individual part.

MODEL	
835	

ITEM	PART NO.	1	2	3	4	5	DESCRIPTION	QTY	
68									
69									
70	15483-G1						NUT, SLOTTED, 5/8 - 18		2
71	10387-G1						PIN, COTTER, 1/8 X 1 1/2 LG.		2
72	30421-G1						TIRE AND WHEEL ASSEMBLY (INCLUDES ITEMS 73 - 75)		
73	30422-G1						TIRE, 4.80 X 8, 6 PLY		1
74	19350-G1						RIM, WHEEL		1
75	11657-G1						STEM, VALVE		1
76	14723-G1						NUT, LUG, 1/2 - 20		10
77	32641-G1						SPACER, WHEEL		2
78	**						KIT, SLIDE HAMMER		NA
79	**						TOOL, SEAL REMOVAL		NA
	**						SEE APPENDIX FOR SERVICE ACCESSORIES AND SPECIAL TOOLS		

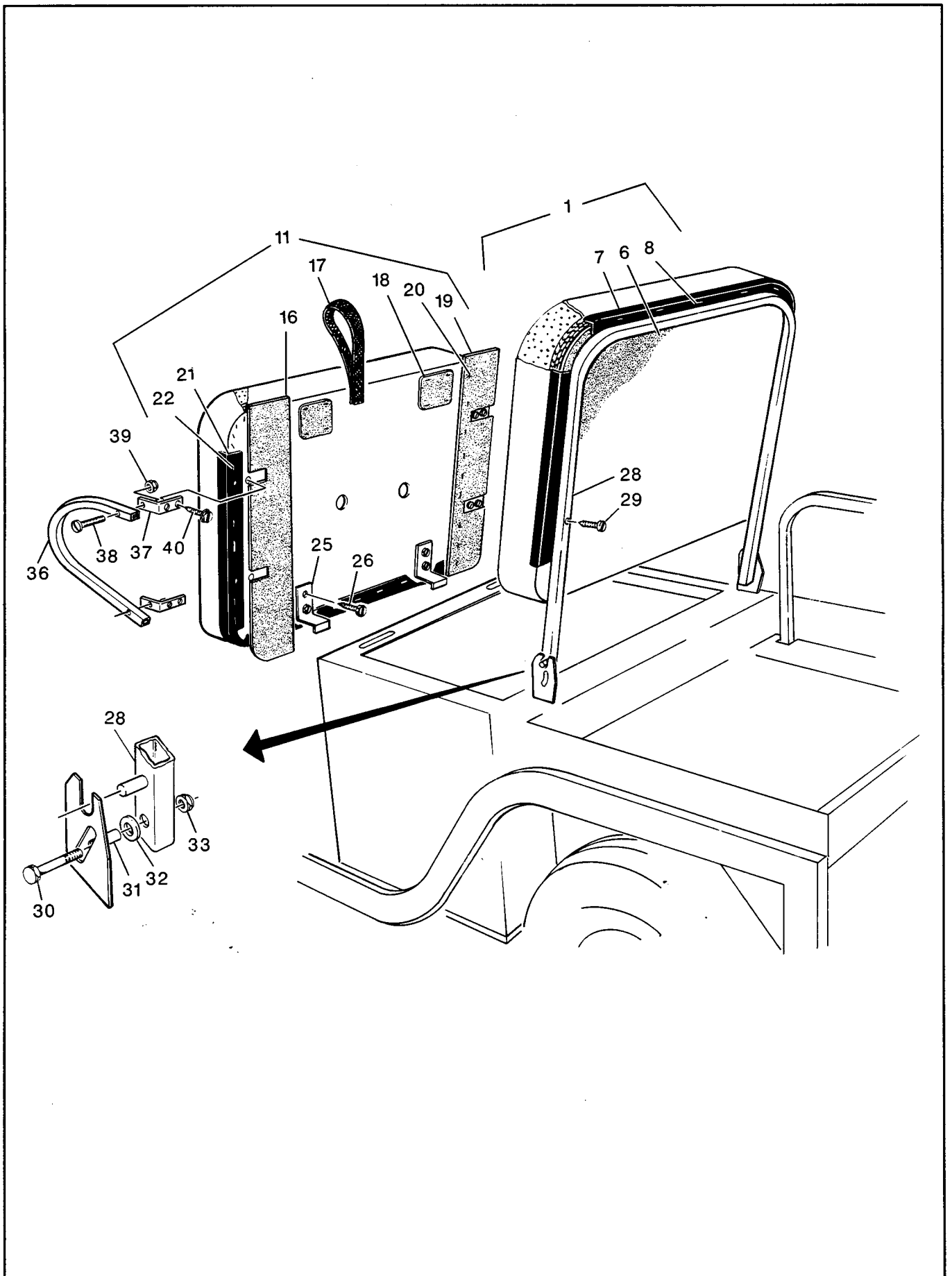

SEATING

THE USE OF NON U.L. PARTS WILL VOID ANY U.L. LISTING.

When ordering parts, please specify the model and serial number of the product.

* Indicates a component that is not available as an individual part.

MODEL	
835	

ITEM	PART NO.	1	2	3	4	5	DESCRIPTION	QTY	
1	32338-G1						SEAT BACK ASSEMBLY (INCLUDES ITEMS 6 - 8)	1	
2									
3									
4									
5									
6	32296-G1						COVER, SEAT BACK	1	
7	32294-G1						TRIM, VINYL	1	
8	*						STAPLE	13	
9									
10									
11	32339-G1						SEAT BOTTOM ASSEMBLY (INCLUDES ITEMS 16 - 22)	1	
12									
13									
14									
15									
16	32293-G2						TRIM, SEAT, L.H.	1	
17	11394-G1						STRAP, WEBBING	1	
18	17074-G1						SLAB, SOILING	2	
19	32293-G1						TRIM, SEAT, R.H.	1	
20	23221-G1						STAPLE, STAINLESS STEEL, 3/4	30	
21	32294-G1						TRIM, VINYL	1	
22	*						STAPLE, STAINLESS STEEL, 5/8	13	
23									
24									
25	18250-G1						HINGE, SEAT BRACKET	2	
26	00115-G2						SCREW, SELF TAPPING, 1/4 - 10 X 1 1/4 LG.	4	
27									
28	32348-G1						FRAME, SEAT	1	
29	00917-G6						SCREW, #14 - 10 X 1 3/4 LG.	4	
30	00439-G8						SCREW, 5/16 - 18 X 2 LG.	2	
31	11906-G1						SPACER	2	
32	00771-G2						WASHER, NYLON, 1/2	2	
33	11098-G6						NUT, LOCK, 5/16 - 18	2	
34									

SEATING

THE USE OF NON U.L. PARTS WILL VOID ANY U.L. LISTING.

When ordering parts, please specify the model and serial number of the product.

* Indicates a component that is not available as an individual part.

MODEL		
	835	

ITEM	PART NO.	1 2 3 4 5					DESCRIPTION	QTY		
35										
36	32463-G1						HOLD, HAND			2
37	32461-G1						BRACKET, HAND HOLD			4
38	00900-G3						SCREW, STAINLESS STEEL, 1/4 - 20 X 1 3/8 LG.			4
39	00891-G2						NUT, LOCK, 1/4 - 20			4
40	00115-G2						SCREW, SELF TAPPING, 1/4 - 10 X 1 1/4 LG.			8

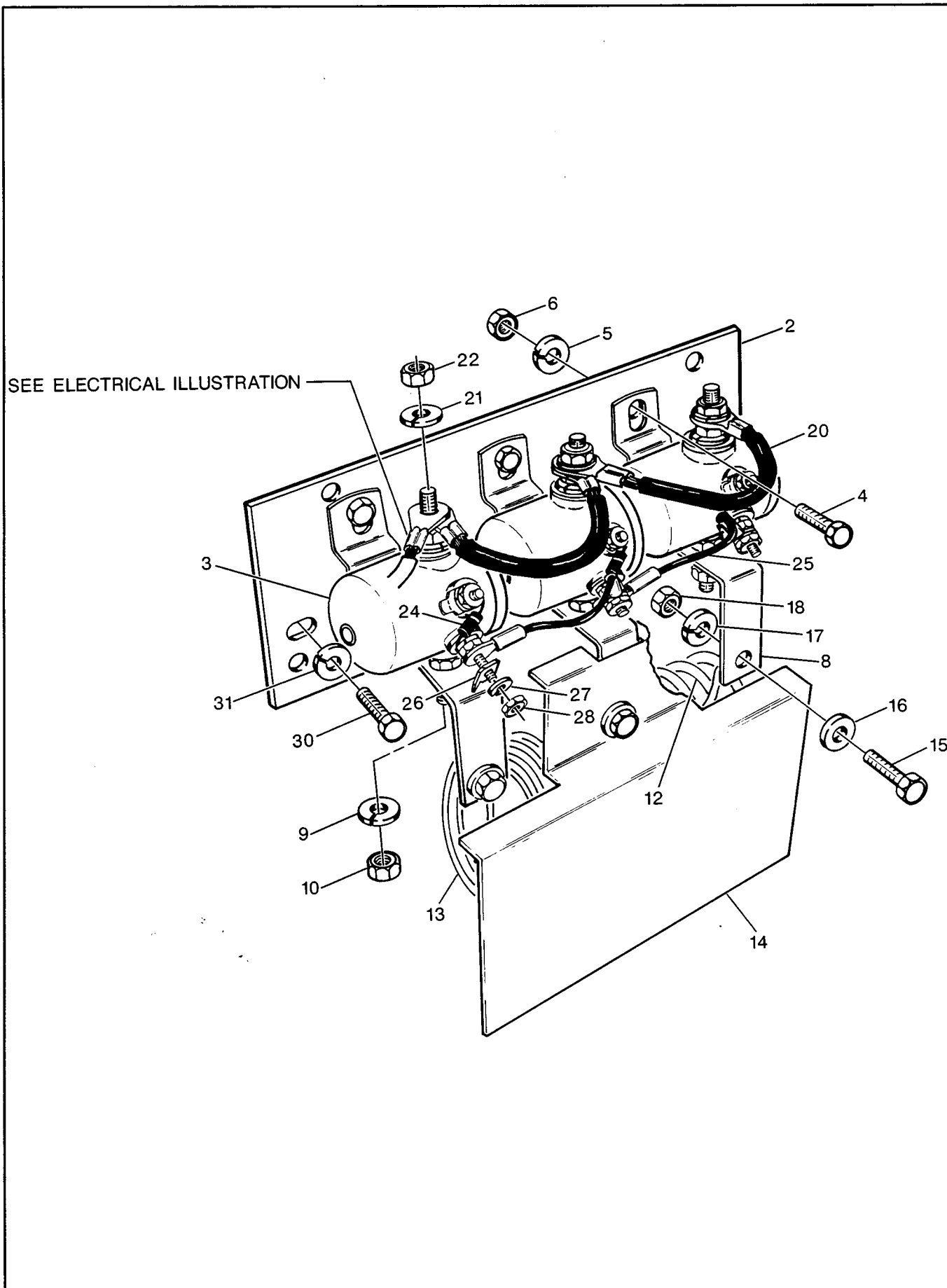

SOLENOIDS AND RESISTORS

THE USE OF NON U.L. PARTS WILL VOID ANY U.L. LISTING.

When ordering parts, please specify the model and serial number of the product.

* Indicates a component that is not available as an individual part.

MODEL		
	835	

ITEM	PART NO.	1	2	3	4	5	DESCRIPTION	QTY		
1	32065-G1						SOLENOID AND RESISTOR ASSEMBLY (INCLUDES ITEMS 2 - 28) .		1	
2	32063-G1						PANEL, SOLENOID		1	
3	30807-G1						SOLENOID		3	
4	00414-G5						SCREW, 1/4 - 20 X 5/8 LG.		6	
5	00565-G7						WASHER, LOCK, 1/4		6	
6	00532-G1						NUT, 1/4 - 20		6	
7										
8	32064-G1						MOUNT, RESISTOR		3	
9	00565-G8						WASHER, LOCK, 5/16 LG.		3	
10	00532-G3						NUT, 5/16 - 18		3	
11										
12	30356-G1						RESISTOR COIL, MEDIUM		1	
13	30355-G1						RESISTOR COIL, HEAVY		1	
14	32694-G1						SHIELD, HEAT		1	
15	00438-G8						SCREW, 5/16 - 18 X 1 LG.		3	
16	00559-G8						WASHER, 5/16		4	
17	00565-G8						WASHER, LOCK, 5/16		3	
18	00532-G3						NUT, 5/16 - 18		3	
19										
20	30338-G1						WIRE, 6 GAUGE		2	
21	00565-G8						WASHER, LOCK, 5/16		3	
22	00544-G4						NUT, 5/16 - 24		3	
23										
24	30353-G1						DIODE, 3 AMP		3	
25	32051-G1						WIRE, 16 GAUGE		2	
26	12914-G1						TAB, FASTON		4	
27	00565-G5						WASHER, LOCK, #10		6	
28	00526-G4						NUT, #10 - 32		6	
29										
30	00414-G6						SCREW, 1/4 - 20 X 3/4 LG.		2	
31	00565-G7						WASHER, LOCK, 1/4		2	

SELF-ADJUSTING BRAKES
(DRIVER'S SIDE SHOWN)

NOTE: 1988 SELF-ADJUSTING BRAKES
 FRONT OF VEHICLE ← THIS SHOE ALWAYS FACES FRONT
 REAR OF VEHICLE → THIS SHOE ALWAYS FACES REAR
 INSTALL ADJUSTER SPRING WITH LONG END TOWARD REAR AND CLEAR OF OBSTRUCTIONS

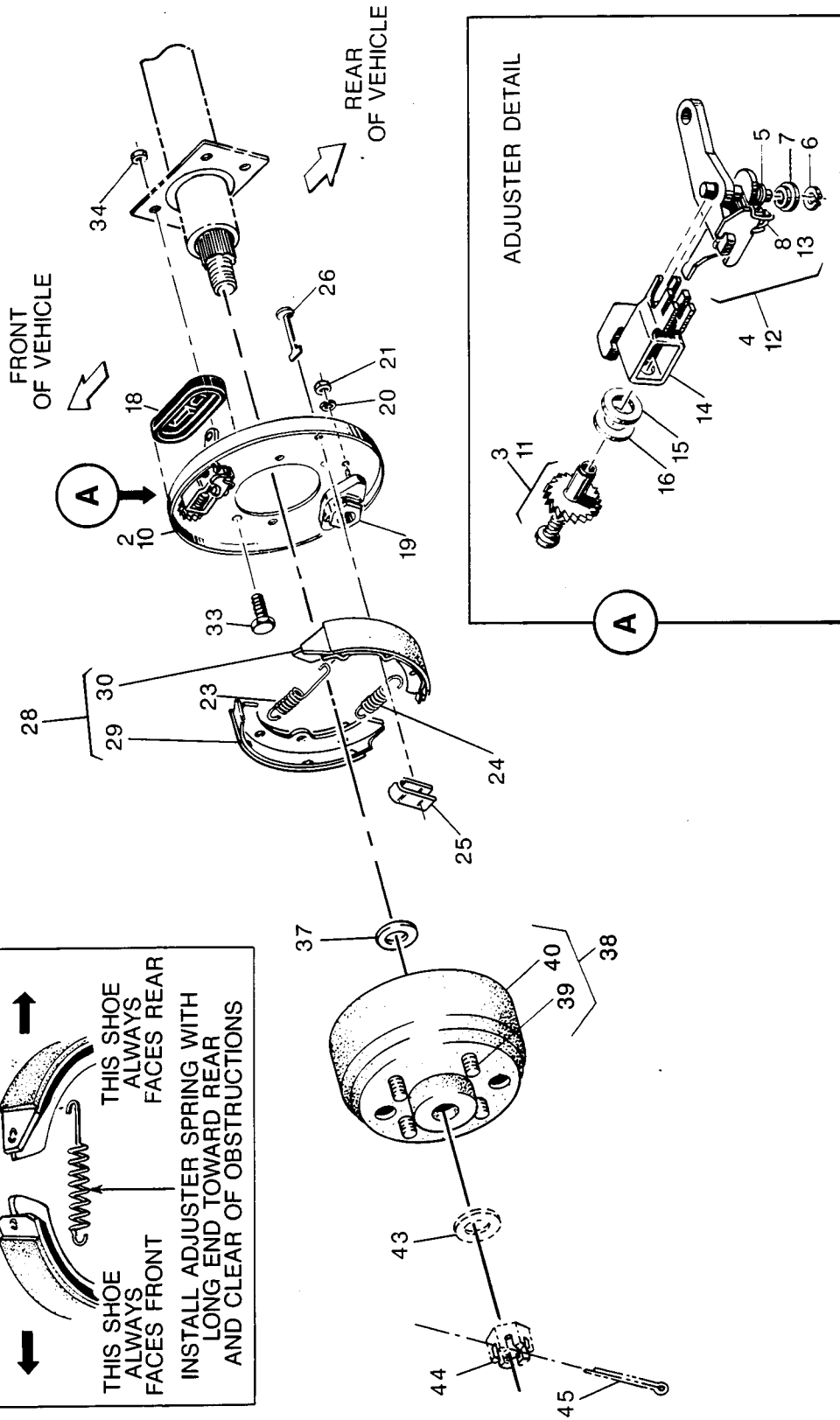

WHEEL BRAKE

THE USE OF NON U.L. PARTS WILL VOID ANY U.L. LISTING.

When ordering parts, please specify the model and serial number of the product.

* Indicates a component that is not available as an individual part.

MODEL		
	835	

ITEM	PART NO.	1	2	3	4	5	DESCRIPTION	QTY	
1	22997-G2						BRAKE ASSEMBLY, R.H. (INCLUDES ITEMS 2 - 8, 14 - 30)	1	
2	22518-G1						PLATE, BACKING, R.H.	1	
3	23360-G1						ADJUSTER ASSEMBLY, R.H.	1	
4	23357-G1						LEVER ASSEMBLY, R.H. (INCLUDES ITEMS 5 - 8)	1	
5	*						SPRING	1	
6	*						RETAINER	1	
7	*						WASHER, SHOULDER	1	
8	23536-G1						SPRING, TORSION, R.H.	1	
9	22997-G1						BRAKE ASSEMBLY, L.H. (INCLUDES ITEMS 10 - 30)	1	
10	22519-G1						PLATE, BACKING, L.H.	1	
11	23361-G1						ADJUSTER ASSEMBLY, L.H.	1	
12	23358-G1						LEVER ASSEMBLY, L.H. (INCLUDES ITEMS 5 - 7, AND 13) ..	1	
13	23537-G1						SPRING, TORSION, L.H.	1	
14	23363-G1						ADJUSTER BODY	1	
15	23382-G1						WASHER	1	
16	23362-G1						WASHER, THRUST	1	
17									
18	22519-G1						COVER, DUST	1	
19	23356-G1						BLOCK, ANCHOR	1	
20	00565-G1						WASHER, LOCK, 1/4	2	
21	13632-G1						NUT, 6 MM	2	
22									
23	23359-G1						SPRING, BRAKE, ADJUSTER	1	
24	17290-G1						SPRING, BRAKE, ANCHOR	1	
25	17291-G1						SPRING, SHOE, CLAMP	2	
26	17292-G1						PIN, TENSION	2	
27									
28	23364-G1						BRAKE SHOE SET	1	
29	23355-G1						BRAKE SHOE, LEADING	1	
30	23354-G1						BRAKE SHOE, TRAILING	1	
31									
32									
33	17083-G1						BOLT, 5/16 - 24 X 3/4 LG.	8	
34	15126-G1						NUT, LOCK, 5/16 - 24	8	

WHEEL BRAKE

THE USE OF NON U.L. PARTS WILL VOID ANY U.L. LISTING.

When ordering parts, please specify the model and serial number of the product.

* Indicates a component that is not available as an individual part.

MODEL		
	835	

ITEM	PART NO.	1	2	3	4	5	DESCRIPTION	QTY		
35										
36										
37	15485-G1						WASHER			2
38	19186-G2						BRAKE DRUM ASSEMBLY (INCLUDES ITEMS 39 - 40)			2
39	17126-G2						BOLT, LUG			4
40	*						DRUM, BRAKE			1
41										
42										
43	XXXX-XX						WASHER (SEE PAGE 98 FOR PART NUMBER AND QUANTITY)			
44	XXXX-XX						NUT, SLOTTED (SEE PAGE 98 FOR PART NUMBER AND QUANTITY)			
45	XXXX-XX						PIN, COTTER (SEE PAGE 98 FOR PART NUMBER AND QUANTITY)			

SERVICE ACCESSORIES AND SPECIAL TOOLS

SPECIAL TOOLS

PART NO.

CURRENT INDICATOR	16489-G2
MULTI-METER (OHM METER)	51020-G2
SEAL INSTALLATION TOOL (REAR AXLE SHAFT SEAL)	18739-G1
SLIDE HAMMER KIT (AXLE PULLER)	18753-G1

PAINT

CONTACT CUSTOMER REPRESENTATIVE FOR COLOR SPECIFICATIONS AND PART NUMBERS.



E-Z-GO Division of Textron Inc.
P.O. Box 388 Augusta, Georgia 30903-0388
Telephone 1-800-241-5855

Copyrighted material.
This manual may not be reproduced in whole or
in part without the express permission of
E-Z-GO Division of Textron Inc.
Technical Communications Department